

MANUAL

ON Renewable Energy Technologies

For Sustainable Energy Solutions To Reduce Poverty In South Asia



INF  RSE-South ASIA

International Network for Sustainable Energy

ALL RIGHTS RESERVED

This publication is the joint property of INFORSE–South Asia and INSEDA. Copying either wholly or partly, using manually or electronically or by any other means, and/or transmitting portions or all of this work without prior permission would be a violation under applicable law and statues. Requests for permission to photocopy or reprint any part of this work should be obtained in advance, in writing and sent to the INFORSE Regional Coordinator (South Asia)/Secretary General-cum-Chief Executive of INSEDA, on the addresses given at the bottom of this page. INFORSE–South Asia and INSEDA encourage dissemination of their work and will normally give permission, when the reproduction is for non-commercial purposes, by charging reasonable fees.

Er. Raymond Myles: INFORSE Regional Coordinator (South Asia) and
Secretary General-cum-Chief Executive, INSEDA

Address: House No: C-37, First Floor, Next to Car Life Centre, Jeewan Park, Pankha
Road, Uttam Nagar, New Delhi-110059, India

Ph: 6450 0730; Telefax: +91 11-2554 4905

Mobile: (0) 9212014905 and (0) 9899094905

E-Mail: raymyles@bol.net.in; ray.myles06@gmail.com; and
inseda_inforse@vsnl.net.in

INFORSE Website: <http://www.inforse.org/asia> and www.inforse.org

INSEDA Website: <http://www.inseda.org> and <http://www.inseda.info>

For enquiries & orders: Contact INFORSE Regional Coordinator (South Asia)

or

INFORSE International Secretariat, Denmark at address given
below:

INFORSE-Europe and INFORSE International Secretariat,
Attn: Gunnar Boye Olesen, Coordinator INFORSE Europe and INFORSE
International

Address: Gl. Kirkevej 82, DK-8530, Hjortshaj. Denmark

Ph: +45 86227000; Fax: +45 86227096

E-mail: ove@inforse.org and inforse@gmail.com

Website: www.inforse.org

All Rights Reserved

INSEDA, INFORSE South Asia and INFORSE International,

First Edition

January 2007



MANUAL

On

Sustainable Energy Technologies Solutions for Poverty Reduction in South Asia

Published by:

International Network For Sustainable Energy
(INFORSE)–South Asia

(www.inforse.org/asia and www.inforse.org/europe)

Compiled, prepared and edited

by

**RAYMOND MYLES, GUNNAR BOYE OLESEN
AND SANJIV NATHAN**

Partners and Co-compilers

**R. M. AMERASEKERA (IDEA), GANESH RAM SHRESHTA (CRT/N), DIPAL BARUA
(GS) LALITA BALAKRISHNAN (AIWC), FR. MATHEW VADAKEMURIYIL (SDA),
PAUL ERIK BIDINGER (DIB) AND ZAREEN MYLES (WAFD)**

Organizations which supplied the materials and actively supported the
preparation of this manual

**INSEDA (INDIA), OVE (DENMARK), INFORSE REGIONAL SUPPORT UNIT (RSU) FOR SOUTH ASIA
(NEW DELHI, INDIA), CRT (NEPAL), IDEA (SRI LANKA), GRAMEEN SHAKTI (BANGLADESH),
AIWC (INDIA), SDA (INDIA), DIB (DENMARK) AND WAFD (INDIA)**

Contact to publisher: see www.inforse.org/asia

JANUARY 2007



Contents

Acknowledgements

Preamble

1 Introduction

<u>Sustainable energy choices, value of choosing the right RET solution</u>	<u>1-2</u>
---	------------

2 Guidelines

<u>Choosing right RET solutions</u>	<u>3-8</u>
-------------------------------------	------------

<u>2.1 Discussion of local problems and resources</u>	<u>4</u>
<u>2.2 Status of energy balance and local energy resources</u>	<u>4</u>
<u>2.3 Elaboration of future energy balance (business as usual)</u>	<u>5</u>
<u>2.4 Calculations for single technologies</u>	<u>6</u>
<u>2.5 Calculations of different mixes of technologies</u>	<u>7</u>
<u>2.6 Elaboration of an action plan</u>	<u>8</u>

3 Solutions

<u>Sustainable energy technologies</u>	<u>9-46</u>
--	-------------

<u>3.1 COOKING DEVICES</u>	<u>9</u>
<u>3.1.1 Stoves</u>	<u>10</u>
<u>3.1.1.1 "Anagi" Stove Construction in Sri Lanka</u>	<u>10</u>
<u>3.1.1.2 Improved Cook Stoves in India</u>	<u>10</u>
<u>3.1.1.2.1 Improved Cook Stove (Udairaj model, India)</u>	<u>11</u>
<u>3.1.1.2.2 Improved Cook Stove (Laxmi model, India)</u>	<u>11</u>
<u>3.1.1.3 Improved Cook Stove– (CRT model, Nepal)</u>	<u>12</u>
<u>3.1.1.4 Stoves for Using Honey Comb/Beehive Briquettes</u>	<u>12</u>
<u>3.1.2 Biogas Technology</u>	<u>14</u>
<u>3.1.2.1 Floating Gas Holder Biogas Plant</u>	<u>16</u>
<u>3.1.2.2 Fixed Dome Biogas Plant</u>	<u>16</u>
<u>3.1.2.3 Flexible Bag Biogas Plant</u>	<u>16</u>
<u>3.1.3 Solar Cookers</u>	<u>16</u>
<u>3.1.3.1 Box Type Solar Cooker</u>	<u>17</u>
<u>3.1.3.2 Solar Baking Unit</u>	<u>17</u>
<u>3.1.3.3 Community Solar Cooker</u>	<u>18</u>
<u>3.1.3.4 Community Solar Cooker (Scheffler)</u>	<u>18</u>
<u>3.1.4 Charcoal and Briquetting</u>	<u>19</u>
<u>3.1.4.1 Portable Charring Kiln</u>	<u>19</u>
<u>3.1.4.2 Honeycomb/Beehive Briquettes</u>	<u>20</u>
<u>3.1.4.3 Low Cost Briquetting Machine</u>	<u>20</u>
<u>3.1.5 Hay Box Cooker</u>	<u>20</u>
<u>3.2 ELECTRICITY & MECHANICAL DEVICES</u>	<u>21</u>

<u>3.2.1</u>	<u>Solar Photovoltaic Systems</u>	<u>22</u>
<u>3.2.1.1</u>	<u>Solar Lantern</u>	<u>23</u>
<u>3.2.1.2</u>	<u>Solar Home Systems</u>	<u>23</u>
<u>3.2.1.3</u>	<u>Solar Street Light</u>	<u>24</u>
<u>3.2.1.4</u>	<u>Solar Pump</u>	<u>24</u>
<u>3.2.1.5</u>	<u>Solar Tracking Device</u>	<u>25</u>
<u>3.2.1.6</u>	<u>Solar Photovoltaic Refrigerator</u>	<u>25</u>
<u>3.2.2</u>	<u>Micro Hydro Systems</u>	<u>26</u>
<u>3.2.3</u>	<u>Biomass Based Power Generation</u>	<u>26</u>
<u>3.2.4</u>	<u>Windmills for Electricity and Pumping</u>	<u>28</u>
<u>3.2.5</u>	<u>Animate Energy</u>	<u>29</u>
<u>3.2.5.1</u>	<u>Treadle Pump (Krishak Bandhu Pump)</u>	<u>29</u>
<u>3.2.6</u>	<u>Electricity Conservation</u>	<u>30</u>
<u>3.2.6.1</u>	<u>Electricity Conservation Tips</u>	<u>30</u>
<u>3.3</u>	<u>OTHER DEVICES</u>	<u>31</u>
<u>3.3.1</u>	<u>Drying</u>	<u>31</u>
<u>3.3.1.1</u>	<u>Domestic Solar Dryer</u>	<u>31</u>
<u>3.3.1.2</u>	<u>Step Type Solar Cocoon Stifler</u>	<u>32</u>
<u>3.3.1.3</u>	<u>Simple Pyramid Shaped Dryer</u>	<u>32</u>
<u>3.3.1.4</u>	<u>Data on Solar Dehydration of Selected Foods</u>	<u>33</u>
<u>3.3.2</u>	<u>Solar Water Heater</u>	<u>33</u>
<u>3.3.3</u>	<u>Solar Distillation</u>	<u>35</u>
<u>3.3.4</u>	<u>Solar Disinfection and Purification of Water</u>	<u>35</u>
<u>3.3.5</u>	<u>Solar powered drinking water UV disinfection unit</u>	<u>36</u>
<u>3.3.6</u>	<u>Passive Cooling and Heating of Rooms</u>	<u>36</u>
<u>3.3.6.1</u>	<u>Solar Passive Techniques</u>	<u>37</u>
<u>3.3.6.2</u>	<u>Passive Solar Heating</u>	<u>38</u>
<u>3.3.6.3</u>	<u>Tromb� Wall</u>	<u>40</u>
<u>3.3.6.4</u>	<u>Passive Solar Cooling</u>	<u>41</u>
<u>3.3.7</u>	<u>Bio Diesel</u>	<u>42</u>
<u>3.3.7.1</u>	<u>Technical Feasibility</u>	<u>43</u>
<u>3.3.7.2</u>	<u>Sources of Bio-Diesel</u>	<u>43</u>
<u>3.3.7.3</u>	<u>Indian States that promoted Bio-diesel considerably</u>	<u>44</u>
<u>3.3.8</u>	<u>Electravan</u>	<u>45</u>
<u>3.3.9</u>	<u>Fuel Wood Plantation</u>	<u>46</u>

4 Organizations

<u>Local organizations managing sustainable energy</u>	<u>(14 examples)</u>	<u>47-62</u>
--	----------------------	--------------

Annexure- A

<u>Tables used in calculations in Chapter- 2</u>	<u>(15 Tables)</u>	<u>63-68</u>
--	--------------------	--------------



Acknowledgements

This manual has been prepared as a part of the International Network for Sustainable Energy (INFORSE)–South Asia project for “Capacity Building of NGOs for Poverty Reduction in South Asia through Sustainable Energy Solutions”, funded by ‘The NGO Counselling Service’, Denmark. The main partners of the project are: INSEDA (India); Grameen Shakti (Bangladesh); CRT/N (Nepal); IDEA (Sri Lanka); AIWC and SDA (India); OVE (Denmark) and DIB (Denmark).

The Regional Coordinator, INFORSE -South Asia wishes to acknowledge the contribution of several individuals and organizations who contributed through ideas and comments etc., as well as by providing write-up on best practices and case studies related to sustainable energy solutions, and support and feedback for the revision and finalization of this manual. The names of some of the major contributions, are mentioned below:

WAFD (India) who is grassroots NGO member of INSEDA and INforSE, for providing critical inputs, field data from its 12 Eco-villages development project (Bharatpur Dist of Rajasthan state), which were used as the basis for working out a practical example for realistic calculations using the method used in chapter-2- “Choosing the right solutions” as well as, for the on going and logistic support in the preparation of the manual.

Individuals and organizations who contributed or provided ideas, case studies, comments and inputs, are Judit Szoleczky (Co-editor, Sustainable Energy News, INFORSE) from Denmark; Prakash Manwar and Meenu Mishra, (INSEDA-RSU); Manjushree Banerjee (AIWC) & Niranjana Sharma (SOHARD) from India; Rajendra Pradhan (SOLVE) from Nepal; and, Dr. (Fr.) KT Chandy, Principal, Jaluki Agricultural Collages (Nagaland), India.

The INSEDA- INFORSE SA-RSU Team members who provided logistic, back-up and other ongoing support in the preparation of the manual are, Nalin Chester, J. K. Sharma and Rajender Kumar. Ameet Manwar for providing some of the photos used in the manual, taken during the field visits of INFORSE regional seminar delegates to the projects of two NGO members of INSEDA, in Rajasthan state, India.

Major assistance in layout, proof reading and printing of the final manual as well as layout of the design for the CD label to the Regional Coordinator, INFORSE, South Asia-cum-Project Director (Regional Support Unit-RSU), was provided by the INSEDA team consisting of Sanjiv Nathan, J. K. Sharma and Manoj Soni.

Raymond Myles

Regional Coordinator (INFORSE-South Asia) and
Project Director (INFORSE Regional Support Unit-RSU)

January 1, 2007



Preamble

Renewable energy and energy efficiency are developing fast throughout the world, and their combination is increasingly able to meet the needs for available, agreeable, and affordable energy, also for the people that lack access to energy today. In addition, local energy resources are not hit by the high energy prices which are ever increasing and are threatening to reverse the progress in providing energy to the poor people that lack appropriate energy today. This is why sustainable energy, a combination of renewable energy and energy efficiency, is increasingly becoming an integrated part of the global and more particular the NGO community for reducing poverty in the developing countries.

This manual gives an overview of sustainable energy technologies (SETs) that can contribute to reducing poverty and in providing energy for the poor in South Asia. No one person needs all the solutions that the manual covers; but everybody needs some. The manual gives guidance on how to choose the right combination of sustainable energy solutions. This manual is part of a collection and compilation of materials developed to assist NGOs to work with sustainable energy solutions to reduce poverty. The collection also includes cases describing the practical usage of the sustainable energy technologies, a financial manual for financing local energy solutions, as well as background materials and related documents. These other parts of the collection published in English on a CD. All these materials are also available on Internet at <http://www.inforse.org/asia> in English.

Chapter-2 of this manual describes briefly a way to compare different solutions and to develop a strategy for better energy supply for a given village. This is included to help NGOs and others involved in the field of development assistance to reduce poverty through the recommendation of best solutions. The chapter should be used together with other available materials and the methods normally used in planning for the development, such as gender sensitive evaluation of effects and integrated development methods.

The chapter-3 describes the most important sustainable energy technologies (SETs) for poverty reduction in South Asia. Most of the descriptions include basic data on how to use the technologies as well as their costs and benefits. This is important to make a first evaluation about the relevance of the technologies in a given situation. This chapter also describes a number of important issues to consider before choosing a technology, such as: need for inputs, need for spare-parts and maintenance, typical problems, etc. It cannot, however, cover all local issues, such as local availability of technology, local knowledge or lack of knowledge about the technology and other development issues, with which the local NGOs are already familiar.

The fourth and the last chapter deals with the organizations and local institutions and the brief information about their practical experiences in how they have achieved/ are achieving the goal of poverty reduction through the interventions of renewable energy technology (RET) solutions; and that these solutions have the potential in promoting, replicating and proliferating the sustainable energy solutions and technologies.

In most places the currency used in this manual is Indian rupees (IRP), which is approximately equal to Euro 0.019, US \$ 0.022, N. Rp 1.67, SL Rp. 1.42 & Bnd Taka 1.35.

This manual is published in English, Hindi, Nepalese, Bangladeshi and Singhalese language. The manual is available from the above organizations. It can also be downloaded from <http://www.inforse.org/asia>.



Introduction

1 Sustainable energy choices and value of choosing the right RET solution

Energy is one of the major parameters for establishing growth and progress of the country; rather the standard of living depends upon the per capita energy consumption. Most of energy on the earth is received from the sun. Solar energy creates circulation of wind and ocean water, causes water evaporation and consequent precipitation. Plants use solar energy for photosynthesis and store carbohydrates, protein, fats, oils, alcohols, cellulose and lignin. Humans and animals consume plant materials as primary food to utilize its digestive energy.

While energy is not considered as one of the basic human needs but it positively contributes in the fulfillment of all basic and most essential needs for the survival of man kind. For example one can not think of achieving food and water security; sustainable livelihood for the poor; provide sustainable health services; capacity building, through effective information dissemination and communication services for awareness, up-gradation of knowledge & skills, and imparting appropriate education etc; for the empowerment of the local people in the South Asian and other developing countries, with out first achieving the self sufficiency in energy. Therefore, it can hardly be overemphasized the role of energy services as the key inputs to all the inputs required for the survival of human being and realizing of the developmental goals. Majority of developing countries have to first tackle the energy poverty to be able to combat the wider issue of hunger and poverty, and to achieve positive results in an effective manner.

The energy supply and consumption pattern of a country therefore is a vital indicator of the degree of development. At the same time the prevailing trends of energy supply and consumption do seem to disintegrate the very system that it tries to develop thus negating the global development efforts leading towards un-sustainability. The current concerns on green house gas (GHGs) leading to climatic change, acid rains, resource depletion, environmental pollution, unprecedented escalations in energy price, loss of biodiversity, land degradation, soil erosion, deforestation and associated health hazards are some of the examples. In order to mitigate the negative impacts of energy consumption based on depleting, non-renewable, polluting and un-viable fossil fuel and realizing the goals of achieving sustainable development, an increasing share of the energy supply must come from, non-polluting, environmentally benign, people's-friendly, non-depleting, locally-available, renewable energy resources, such as biomass, solar & wind etc. In addition, the available energy has to be conserved and used more efficiently and judiciously than being used at present.



Analysis of the major distribution of major energy forms in many of the South Asian countries reveals that non-commercial renewable energy meets the energy needs of majority of the people living in the villages, more specifically the rural poor, but in a traditional and inefficient manner at present. Therefore, the new renewable energy technologies (RETs) disseminated for adoption, diffusion and internalization by the rural masses need to be improved for efficient utilization and convenience which necessitate selection of right solutions depending on the context of each country, as well as a particular region within the country. The chart below gives the commercial and renewable energy use pattern of four South Asian countries.

South Asian Countries	Percentage of Renewable Energy (mainly in traditional and inefficient manner)
India	80%
Sri Lanka	63%
Nepal	97%
Bangladesh	95%

The broad break-up of major energy forms in India are, 65% non-commercial energy, 15% human and animal energy, where as, the use of commercial energy is 20%- thus, the 80% of the rural energy needs of India is met from renewable sources, mainly biomass in a traditional an inefficient manner.

The contribution/share of renewable energy in the rural areas of Sri Lanka is 63%.

“Most of energy on the earth is received from the sun. Solar energy creates circulation of wind and ocean water, causes water evaporation and consequent precipitation. Plants use solar energy for photosynthesis and store carbohydrates, protein, fats, oils, alcohols, cellulose and lignin. Humans and animals consume plant materials as primary food to utilize its digestive energy. Plant and animal remains are converted to coal and petroleum products over million of years, which provide the main energy sources for modern life. In agricultural systems, energy is available from different sources as human, animal, sun, wind, biomass, coal, fertilizer, seed, agro-chemicals, petroleum products, electricity, etc. Energy sources that release available energy directly to the system (through mechanical/chemical/biological processes) are classified as direct energy sources. Typical examples of direct energy sources are human labour, animal labour, petroleum products and renewable energy. Some energy is invested in producing indirect sources of energy, such as seed, manure (farm yard and poultry), agro-chemicals, fertilizers and machinery”

For the year 2003/04, total rural energy consumption of Nepal was 288 million GJ of which the rural residential consumed 97%. From end use perspective, out of the total energy consumed in rural Nepal, the 63.9% was used for cooking, heating accounted for 8.5%, lighting 1.31%, agro processing 3.4%, animal feed preparation 16.5% and others such as religious occasions and ceremonies 4.3%.

More than 80% of total population of the country lives in rural areas. At present major portion of total energy needs is met by locally produced biomass fuels which is mostly consumed in the house hold sector for cooking, ongoing rural electrification program meets a small portion of total energy needs. Only 30% (10% rural & 20% urban) people are receiving conventional electricity and 70% are deprived of it. The share of renewable energy in the rural areas of Bangladesh is estimated to be 95%.



Guidelines

2 Choosing right RET solutions

Without energy, development is hardly possible, and the goals of developing rural areas and reduce absolute poverty by half cannot be reached. For the countries in the South Asian region, the energy imports are increasingly costly, and meeting the import needs of fossil fuel for the developing countries in the coming years could become more and more difficult. Fortunately there are ways where local energy sources and efficient use of energy can be combined to meet development needs.

An important task for each area, village, or even family, is to choose the best solutions among the many options available. They already spend money for energy for light, radios, etc. as well as time to collect and dry fuel etc. The question is how they can spend money and time for energy supply more efficient in the future. In this way they can:

- Get energy services cheaper than before. Thus there will be more money for consumption.
- Creation of new work places (this gives a rise in welfare if some people are unemployed) producing energy producing equipment and using renewables and local fuels in stead of importing fuels into the village. Local labour force and local fuels will then replace purchased fuels and salaries will stay in local business.

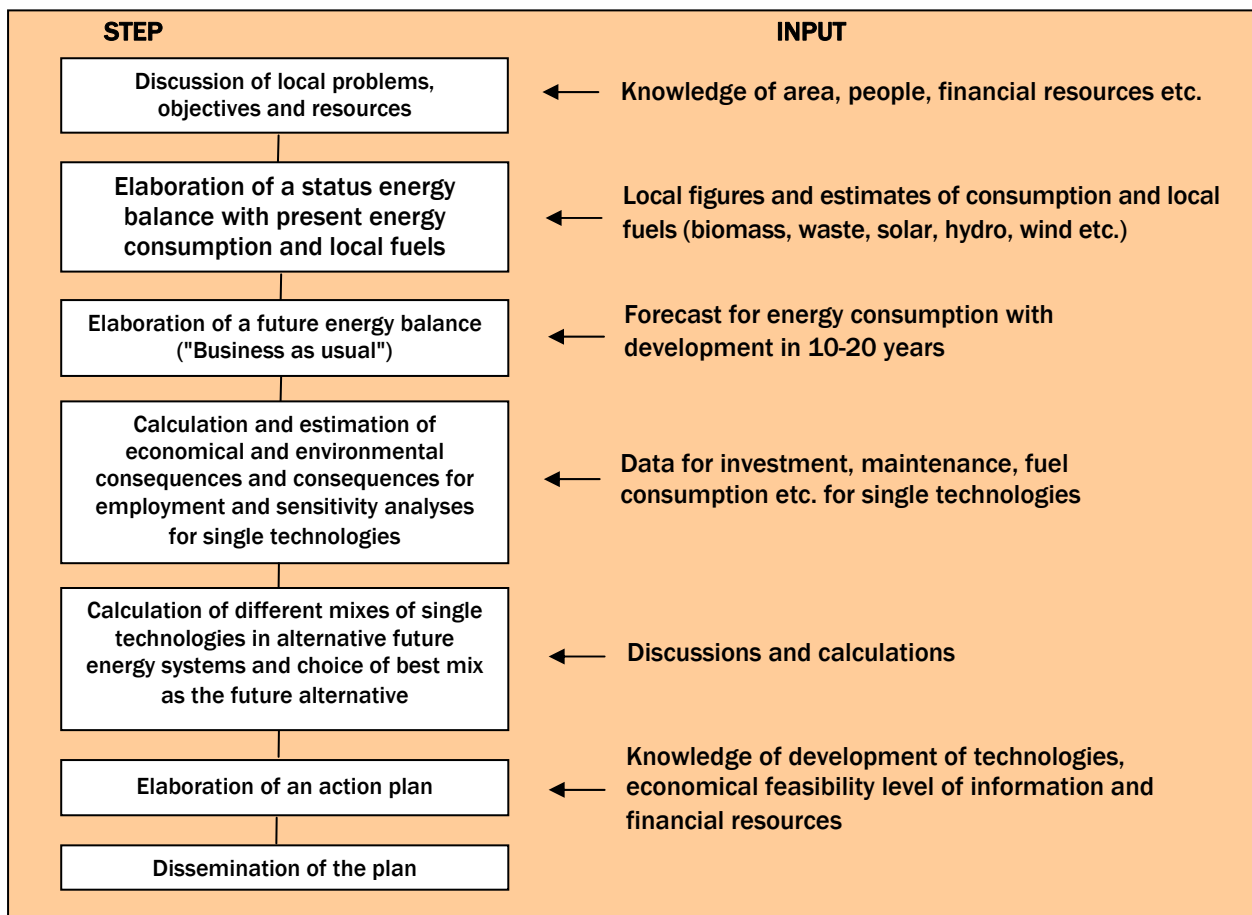

- Reducing the environmental problems and thus reduction of health problems, such as less smoke in the kitchen.
- Developing technologies, learning to use new technologies and achieving new skills.



To choose the right solutions they need to calculate and estimate the consequences for the options they have. This can be done in a number of steps as given in box above:

2.1 Discussion of Local Problems and Resources

The best energy solutions differ widely from place to place, depending on local problems and resources. The process must start with discussions on local problems for development, involving those that will be covered by the proposals, local leaders, local business and administration etc. It is important to discuss:

- What are the main current and potential problems regarding energy supply (e.g. expensive energy, unstable supply, smoke from cooking, etc.)?
- For whom the proposals and plans are made?
- Which consequences are needed to analyze?
- What are environmental problems in the area (such as deforestation, lack of fuel wood, drought, etc.)?
- What are major social problems in the area (illnesses, food shortage, illiteracy, etc.)?
- What are available financial resources and people's ability to pay for energy?
- What are main objectives for development in the area (such as increased employment, increased local independence of energy imports, stop environmental degradation, improved village facilities, improved security, etc.)?

The discussions should lead to conclusions for each issue and pave the way for the next phases of the development.

2.2 Status of Energy Balance and Local Energy Resources

The "energy balance" of a village or family is the abbreviation used for energy consumption and sources. All types of energy are converted to same unit for comparison, and estimates of efficiency are included. Examples of sources and consumption are shown in box aside.

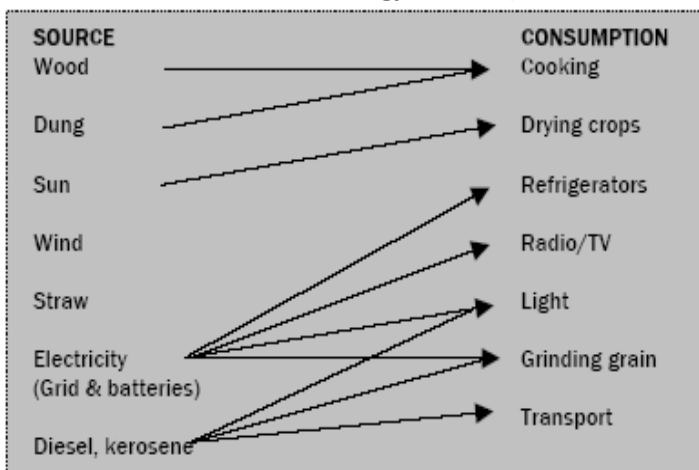

Each arrow shows the present flow of energy. Some sources have many uses, such as electricity, while other sources have no current use such as wind and straw. When the energy flows are found, their size should be found as precise as practical possible. This could be as shown in the box below:

50 families collect 4 kg wood daily for cooking, 200 kg/day = 72 t/year	= 324,000 kWh/year
30 families use 2 kg dry dung daily for cooking, 60 kg/day = 22 t/year	= 65,000 kWh/year
25 families use 1 kg agricultural residues for cooking, 25 kg/day, 9 t/y.	= 36,000 kWh/year
5 families use one gas bottle (14,5 kg gas) per year for cooking, 72 kg/year	= 800 kWh/year
50 families use 4 batteries per month each (2 D-size, 2 AA-size), 2400 /year	= 36 kWh/year
5 families use 25 kWh/month of grid electricity each, 50 kWh/month	= 1500 kWh/year
Health clinic +village head's office uses 75 kWh/month grid electricity	= 900 kWh/year
Village grinder use 400 kWh during the season	= 400 kWh/year
45 families use 2 ltr/month kerosene for light each, 1080 ltr/year	= 10,800 kWh/year
Village grinder uses 1000 ltr. diesel per year at power outage	= 10,000 kWh/year
A tractor in the village use 6000 ltr/year	= 60,000 kWh/year

Next step is to divide use of electricity into use for light, radio/TV, etc. (see [Annex-A](#)). Then an energy balance for the village can be made, (see [Annex-A](#)).



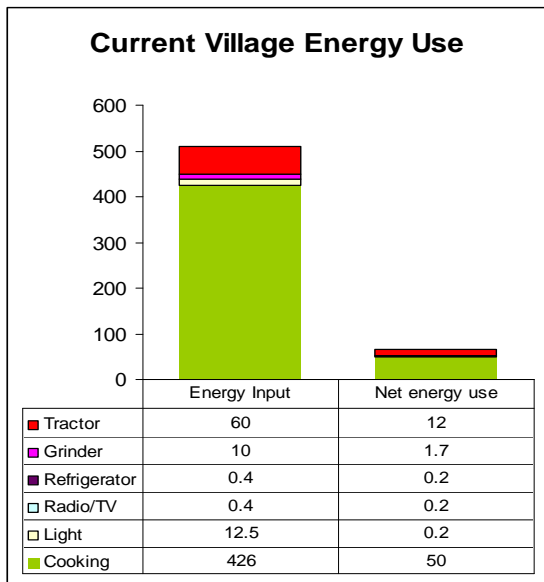

The main energy input and uses from the energy balance are shown in Figure.2.1. The total energy consumption in the village is 509,000 kWh (509 MWh), as calculated in annex A. The right column is end-use energy that gives an overview of how much the consumption needs to be without losses in consumption.

It is clear from the energy balance that current energy use is mainly for cooking and heating. It is also clear that the energy use is inefficient: most of the energy, coming from the wood, diesel, electricity, etc., is lost in the conversion to heat in food, movements of the tractor, light, etc.

Figure.2.1: (Energy in 1000's of kWh= MWh/year), total 187 MWh/year

From the energy balance can be calculated energy costs, workload and CO₂ emissions for the fuel and electricity, based on prices for batteries, grid electricity, diesel, kerosene, and what (some) villagers pay for firewood. It is also calculated how much of this stays in the village as payment and profits to people. Calculations are shown in [Annex-A](#). The costs for the villagers and the employment effects of the current energy use are:

Total energy costs for village: Indian Rs. 286,000 (IRP) of which Rs. 16,000 stays in the village

Total work in village: 130 hours/day, mainly to collect wood & dung

(All figures from Annex A are rounded to 1000's of Rs. & to 1000's or 100's of kWh in this chapter)

Another part of the basis for a local energy strategy is an estimation of available resources. Summary of resources could be:

1. Water stream available for Pico hydropower plant, 2 kW permanent power
2. Dung from 60 cows and 60 buffaloes, partly used today as fuel
3. Dry land that could be planted with energy crops, 2 hectare (20,000 m²)
4. Straw, 20 tonnes/harvest.
5. Solar energy, 1800 kWh/m²

2.3 Elaboration of Future Energy Balance (Business as Usual- BAU)

The present situation in the village is not satisfactory. In the future all households would like to change to grid electricity and use the same energy that the three households with grid electricity use today. They find that they could afford the electricity instead of buying batteries and kerosene, but they cannot necessarily afford the connection fee. In addition the village will invest in a water pump for drinking water, a cold storage, and 4 street lamps. No investment in energy efficiency or local energy supply is expected in the BAU situation.

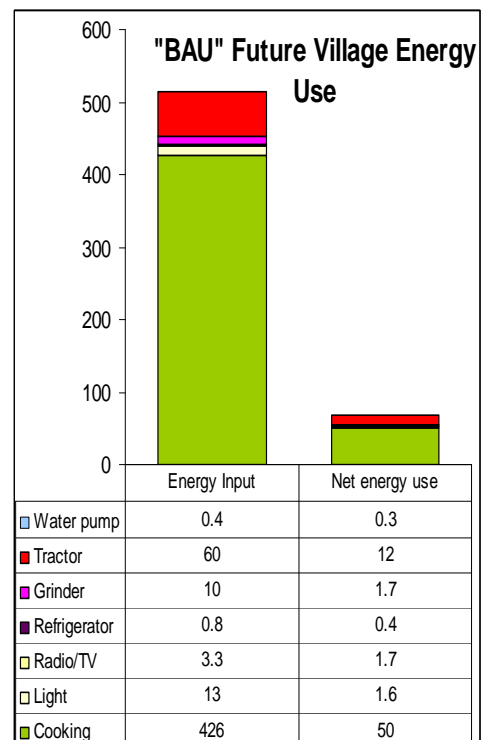

Figure.2.2: Energy in 1000s of kWh= MWh/year)



The energy consumption of the new situation is entered in the table for the energy balance in Annex-A. In this example consumption of grid electricity goes up while consumption of kerosene is stopped and battery use reduced to half.

The future “BAU” energy use is calculated in Annex A and shown in Figure.2.2. Since no changes were made to energy for cooking and heating that are the largest types of energy consumption, little change can be seen in the figure, total energy input increases to 514,000 kWh = 514 MWh. From the detailed energy balance (see [Annex-A](#)) can be seen that electricity consumption increases from 1900 kWh/year to 17,500 kWh/year and consumption of kerosene goes down with 1080 ltr/year. The end-use energy (net energy use) for light and Radio/TV goes up from 410 kWh/year to 3300 kWh which shows that people would have much more light and radio/TV if the BAU situation is realized.

The results regarding costs and work for the BAU situation are:

Total energy costs for village (annual): Indian Rs. 419,000 which Rs. 11,000 stays in the village
Total work in village: 130 hours/day, mainly to collect wood and dung.

With these changes the annual energy costs will go up with Indian Rs. 146,000 (almost Indian Rs. 3,000 per family) because of the increased use of electricity.

The expensive batteries and kerosene are exchanged with grid electricity; but the use of light, refrigeration and radio/TV goes up. The BAU has investments, mainly in electric grid/grid connection which also will increase the total cost for the village. The part of the cost that stays in the village is going down because the local shop sells fewer batteries. The business as usual (BAU) forecast does not include improvements, such as cleaner kitchens or more efficient energy use.

Important discussions are if the village can afford this scenario and what benefits and problems that it has (e.g. is it realistic and desired to rely on grid electricity with outages).

2.4 Calculations for Single Technology

A number of sustainable solutions are now suggested. For each of these solutions, the costs and benefits are calculated. Examples:

Pico-hydro, 2 KW:

Investment: Rs. 200,000; Annual costs: Rs. 5000; Energy production: 16,000 kWh/year; Replaces grid electricity at Rs. 4 per kWh; Simple payback: 3.4 years; Additional effects: more reliable than grid, avoids power shortages, needs local electric grid costing additional Rs. 200,000.

Family biogas plants:

Investment: Rs. 35,000; Annual costs: Rs. 2000; Energy production: 12 kWh/day (2 m³ gas/day); Replaces firewood and dung, saves work of 3 hours/day; Additional effect: Cleans kitchen facility.

Solar street lamps:

Investment: Rs. 10,000; Annual costs (replacement battery every 3 yr): Rs. 400; Extra costs compared with normal street lamps: Rs. 3,000; Saves 350 kWh/yr at Rs. 4 per kWh; Simple payback: 3 years; Additional effects: Works during power cut.



Efficient light bulbs for households: [11 Watt replaces a 40 W normal light bulb]

Investment: Rs. 250; Annual cost: 0 (during lifetime of 6 years); Saves 44 kWh/yr (4 hours use/day) and one normal bulb (Rs. 30); Simple payback: 1.2 years; Additional effects: none.



Solar home systems:

Investments: Rs. 45,000; Annual cost (replacement battery every 5 yr): Rs. 1400; Produces 100 KWh/year, can provide electricity for 4 efficient light bulbs 4 hours/day + Radio/TV; Simple payback compared with kerosene (2 ltr/month) and batteries (3 per month): 35 years, but only 11 years if two families share a system. Simple payback compared with grid electricity: 45 years, but only 30 years if savings in local grid is included. (This example of a large solar home system is not economic with these calculations, but it has other advantages: it gives better light and electricity than kerosene and more reliable electricity than grid in many places)

Jatropha plant field of 2 ha to replace oil; modification in truck to run on Jatropha oil; oil expeller/ press + conversion of truck

Investment: Rs. 150,000; Annual cost: picking 4 tons of nuts/year at 5 kg/hour = 800 hours/year of work at Rs. 15/hour = Rs. 12,000; Production 1400 ltr. Jatropha oil with local rainfall conditions, replaces 1300 ltr, diesel oil at Rs. 30/ltr = Rs. 39,000/year. Simple payback is 5.6 years + 3 years when the bushes grow up.

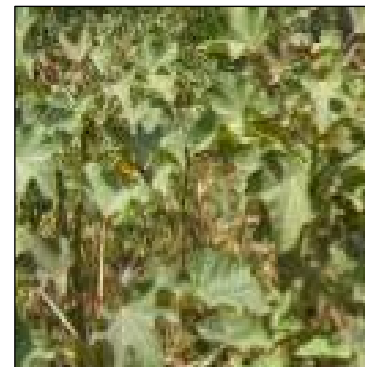

2.5 Calculations of Different Mixes of Technologies

Based on the above descriptions of solutions, some combination of solutions is chosen for further discussions. Examples could be:

Hydropower + efficient light bulbs:

The reason for this is the good economy of the micro-hydro; and that the limitation of the hydro capacity gives a need to save electricity compared with the business as usual scenario, where electricity demand is above the hydro production (16,000 kWh/yr). Investment (including 209 efficient light bulbs: 4 per family (9 Watt each) + street lamps, clinic etc.) Rs. 260,000 (rounded). To that figure must be added investment in wires between houses (the wires are also necessary in the business as usual-BAU scenario), e.g. Rs. 200,000) and capacity limiters, allowing e.g. 40 Watt per house as maximum use.

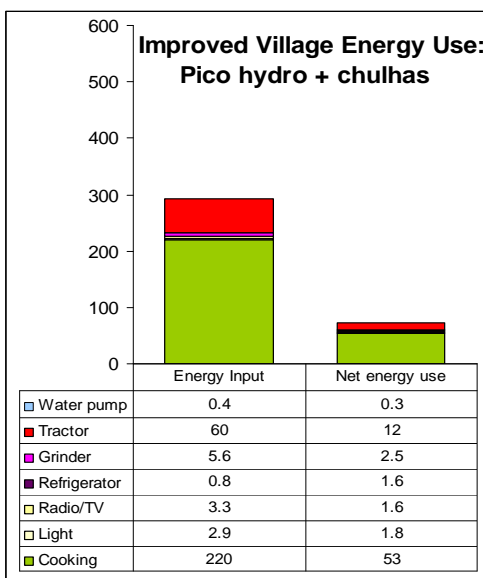

An extended solution is to combine the pico-hydro with improved chulhas for efficient cooking with wood and phase out use of dung and agricultural waste as fuels. With this, the demand for wood fuel is reduced by 1/3, and the demand for dung and agricultural waste etc., is reduced to zero. The energy use with this combination is shown in Figure-2.3. The detailed energy balance and investment calculations are shown in Annex-A. The total energy consumption (293,000 kWh= 293 MWh per year) is lower than the “BAU” example because of the efficient chulhas (cook stoves) and the efficient light bulbs. The net energy use (about 70 MWh/year) is about the same as in the “BAU” example- so the improvements with more lights etc., would be the same. In addition the proposal includes improved kitchen facilities and stopping the use of dung as fuel, so it can be used for improving agriculture.

Figure.2.3: Energy in 1000s of kWh =MWh/year

The results with this example regarding energy cost and work are (from Annex A) given as under:

- Investments: 500,000 Indian Rupees (IRP) of which cash 170,000 (IRP) cash, loans 290,000 (IRP) and subsidy 50,000 (IRP) subsidies (assumed that subsidy will be available).
- Total annual energy costs for village: Indian Rs. 203,000 (IRP) of which Rs. 14,000 (IRP) stays back in the village (this includes repayment of loans of Indian Rs. 32,000).
- Total work in village: 89 hours/day, to collect wood + two hours/day to manage Pico-hydro and the electric grid



In the above example the costs are only 71% of the present costs for energy. This includes estimated repayment of Pico-hydro, mini-grid and efficient light bulbs; but not investments chulhas and improvements (such as cold storage and street lights) that the villagers have to finance in other ways.

Biogas plant and solar:

Another example would be to combine biogas with solar energy. Biogas plants can solve cooking needs and light with gas lamps while and solar can give electricity for Radio/TV. To supply the village, 40-50 family biogas plants are needed with a combined investment of Rs. 690,000. Calculation is shown in Annex-A.

Other examples:

Other systems can also be chosen for calculations such as solar home systems, solar street lamps, Jatropha oil, etc.

When a sufficient number of alternatives are made a decision should be taken with priorities of the different solutions. It is not yet time to make final decisions. They can only be made after an action plan is made. An important part of discussing priorities is that solutions should be presented for and discussed with the people in the village. Then priorities can be made with solutions from the different alternatives. Priorities could be:

1. hydropower and development of local grid
2. development of biogas plants
3. introduction of efficient light bulbs

For each of the suggested solutions should be made a more detailed feasibility study, looking at factors such as uncertainties, variations over the year of demand and supply, subsidies, etc.

2.6 Elaboration of an Action Plan

The action plan should describe how the solutions with the highest priorities can be introduced over a period, how they can be financed, and what the villagers should commit to. It should also propose organizational solutions, uncertainties, and a financing plan.

Then it is time to present the solutions for the people to be involved so they can make their decisions and start improving their situation#.

Disclaimer: Basic data for the example in this chapter are mostly taken from surveys of 12 eco-villages in the Bharatpur district in Rajasthan state of India; but the example does not fully represent any of the existing villages. All use of the methods described in this chapter must be based on the information collected from the actual villages that are analyzed and on local information for costs of energy, equipments etc.



3 Solutions

Sustainable energy technologies

In this chapter various sustainable energy technologies are discussed, which are largely proved to have benefited the people. Some of the technologies are under experimentation. The technologies pertain mainly to cooking, generation of electro-magnet energy and other devices.

3.1 COOKING DEVICES

In rural areas of South Asia, mainly biomass energy (fuel wood, agri-residue and animal dung) is used for cooking and heating purposes. Use of traditional stoves consumes more fuel wood increasing the burden on women, as women are mainly responsible for cooking and collection of biomass. Use of biomass energy and low-grade biomass fuels lead to excessive levels of indoor smoke/air pollution. Women and children in particular are exposed to the smoke emission. This is one of the reasons for higher rates of infant mortality and morbidity and other unhealthy living conditions. Release of carbon dioxide and other harmful gasses in the atmosphere due to poor combustion of biomass fuels in rudimentary stoves resulting into the emission of green house gases (GHGs). More than 80% of the energy needs are met by fuel wood thus exerting immense pressure on the forest resources with negative impacts on environment.

In order to reduce indoor air pollution and increase fuel efficiency as well as protect the forest resources and environment, several initiatives were taken up. As a result of considerable research and development various options are now available such as improved cook stove, biogas, charcoal and biomass briquetting, solar cookers and hay box cooker, etc. which are environmentally sustainable. Though there are advantages and limitations in each option, these are overcome by availability of several models for each technology for cooking purposes.

Although improved cook stove projects (ICPs) have been implemented in Asia since the 1950s, too many projects over long period of time have experienced consistently low adoption rates. This is primarily due to two reasons. One reason is the fact that technical cook stove expertise is still highly centralized. In any Asian country, Nepal and Indonesia are two which stand-out. There may be only one technical expert who is recognized as an improved cook stove designer. Other reason is the improved stoves introduced across a country are often limited to one or two designs. Trainings that have been held in the past have limited themselves to the design and construction of these one or two designs. These designs, although they may be appropriate to the needs, wants and conditions of one target group, will never be appropriate for all possible target groups. There are too many variables involved.

In answer to this problem the Asia Regional Cook stove Program (ARECOP) based in Yogyakarta, Indonesia and the FAO's Regional Wood Energy Development Program (FAO-RWEDP) in Bangkok, Thailand embarked on a collaborative effort to implement Asia regional trainings to decentralize ICP technical skills and programmatic knowledge. This training is different from those before it. It is not designed to transfer particular stove designs or stove building techniques. It invites participants to use a process of selecting a stove and dissemination pattern that does not ignore the multitude of variables which are connected to any stove. These variables include fuels commonly used, available stove materials and their characteristics, economic limitations, gender roles, kitchen size and layout, preferred cooking position, cooking habits, foods commonly cooked, traditions, household industries, non-cooking functions of stoves, combustion theory, heat transfer and heat loss theory.



The training is aimed at improved stove project field workers who are involved in the initial surveys and assessment activities and have the most information to make wise choices in modifying the traditional stove or selecting another improved stove design. The process used cannot be defined as technical or non-technical. It is both, as both must be integrated in the development of an appropriate stove design.

3.1.1 Stoves

In different areas of South Asia, different types of improved cook stoves are developed which have their own merits and demerits but are popular as these are suitable to particular area. While the most popular stoves from Sri Lanka and Nepal are described as below.

3.1.1.1 “Anagi” Stove Construction in Sri Lanka

The most popular ICS in Sri Lanka is marketed under the trade name “Anagi”. Word “Anagi” in Sinhala language means ‘precious’ or ‘excellent’. So “Anagi” stove is an excellent and precious stove because it saves firewood and cooking time provided it is made to the correct dimensions. Lab tests carried out on the stove spell the technical efficiency of 21%, and numerous field-cooking tests tell average firewood savings to be over 30%, twice as good as traditional stoves.

Anagi is two pot single piece clay stove designed to meet the cooking needs of a family of 6 people. It can accommodate medium size hard or soft wood and other loose biomass residues such as coconut shells, fronds and leaves. The stove design has been carefully developed to suit the cooking habits and the types of food cooked in Sri Lanka. The stove can be used directly, which is preferred for short cooking as done in urban houses. For cooking over a long period of time as in many rural houses, insulating the stove with a mud mixture improves the firewood saving capability. The lifetime of the stove may be about 3 years instead of 1 year if used directly without any insulation.

Anagi stove has three main components: (i) Fire box, (ii) 2nd pot hole, and (iii) Tunnel (which connects the firebox and the 2nd pot seat). Likewise, secondary components are: (i) pot rests, (ii) buttresses, (iii) baffle, (iv) flame shield, and (v) the door.

Anagi was first introduced in 1986 by the Ceylon Electricity Board in collaboration with the ITDG under the Urban Stoves Programme. Its success prompted the stove to be selected for commercialization in the rural areas with the participation of the Integrated Development Association (IDEA) and the ITDG. Later, the Asian Cook stove Programme (ARECOP) supported the programme, which got success in installing 300,000 stoves in remote villages.

3.1.1.2 Improved Cook Stove in India

The National Programme on Improved Chulha (NPIC) was started in 1986-87 by Govt. of India as a programme for women, by women & through women with the following objectives:

- Conservation of fuel wood and other biomass;
- Removal of smoke from kitchen;
- Check on deforestation and environmental up gradation;
- Reduction in the drudgery of women and girl children from cooking in smoky kitchen;
- Reduction of health hazards and in cooking time; and
- Provides employment opportunities to rural people.

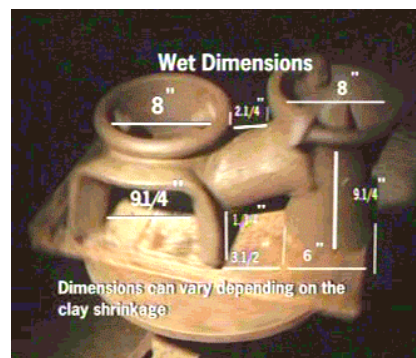

Cumulative Achievement:

- Over 350 Lakh (35 million) Improved Chulhas (as against estimated the total potential of 1200 Lakh or 120 million) up to March 2003 have been installed in various states of India.
- NPIC is implemented with a multi-agency approach.
- Self Employed Workers", mainly women, from Rural & Semi urban area are twist-trained hands on who are providing service for the proper construction and maintenance of the fixed type chulhas.

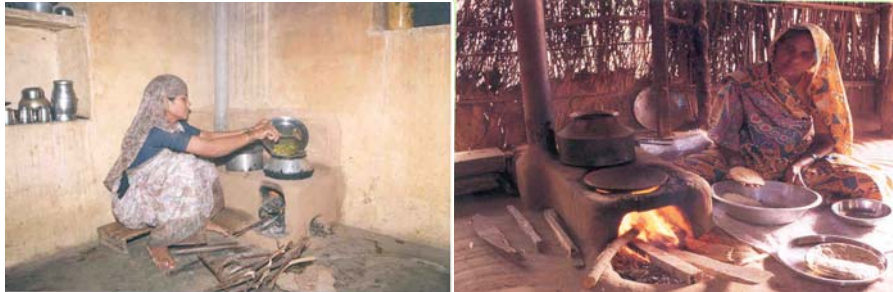

- More than 30 models of durable fixed with chimney and portable improved chulhas are available for family, community and commercial applications.
- There are fifteen manufacturers of ISI marked portable metallic chulhas in the country.

In India several models have been developed and promoted, out of which two models are presented here.

3.1.1.2.1 Udairaj

Udairaj cook stove is a double pot design suitable for burning firewood, dry dung cakes, crop residues and other traditional fuels. Stove is suitable for roasting *chapatti* in open combustion chamber. On the rear of the space for the two cooking pots a chimney has been provided to let off the smoke and products of combustion. The stove is meant for using both the fire pots simultaneously. Construction is of good quality bricks and cement mortar. Additional mud insulation is provided on the exteriors of the stove to reduce skin burn on contact.



3.1.1.2.2 Laxmi

This chulha accepts two pots at a time. It is also provided with a chimney. There are no pot raisers, and because the pots sit flush on the potholes, the flue gases do not escape into the kitchen, but are taken out of the house.



Out of the total heat generated by the fuel, about 60% is available at the first pothole and 40% at the second pothole. It is thus possible to cook food simultaneously on both the potholes. The disadvantage of a two-pot chulha is that a part of the heat is wasted if the second pothole is not used.

3.1.1.3 Improved Cook Stove– CRT Nepal

The type of Improved Cook Stove (ICS) promoted in Nepal is made up of 3-part mud/earth, 2 parts straw/husk and 1 part animal dung. The whole structure is plastered smooth with the same mud mortar. ICS has two fire openings for cooking pots, one behind the other.

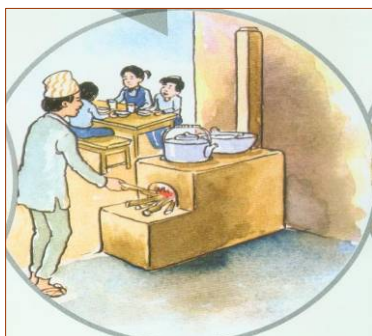

There is no need to blow the fire. It utilizes the heat, generated by burning fuel wood, more by the deflection of the flames and heated air inside it which travel to the second opening with the help of an in-built baffle located just below the second opening, before the hot air exits out of the chimney, which is made of un-burnt clay bricks that can be made in the village. The iron plates are fitted on the potholes for pots. The potholes are round in shape; the pot bottom fits tight on them. It can be made in different sizes and capacities to suit the family size and pot size. It can have one or more openings for pots/pans.

ICS can even be used for space heating by adding a cast iron/mild steel plate put tight over the pot holes for the pots or by putting a metal pipe around the space/room to make the pots or by putting a metal pipe around the space/room to make the hot air pass around the room through the pipe before going out through the chimney. Nowadays, use of ICS for water heating by attaching a back boiler on the side or around the chimney pipe is increasing in the mid-hills and mountain regions of Nepal. The materials required for the construction of ICS are locally available and includes stones/bricks, mud/earth, straw/rice husk, iron plates/ rebar/sheet, animal dung. In addition to the domestic institutional improved cook stoves (ICS), promotion of institutional ICS is being carried out in hotels, teashops, schools, hostels, and barracks.

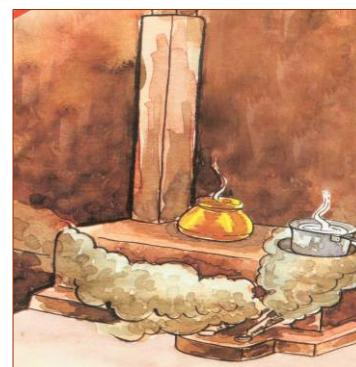

The materials required for the ICS construction are locally available and the users have to bear the cost of iron rod and installation charge only. The cost varies depending upon the place but in general it is approximately 300-400 Nepali rupees.

Problems and Solutions:

ICS is a simple technology based on scientific concept and easy to operate. Users do not face any severe technical problems during its operation. The problems may arise when ICS Promoters do not adhere to the technical specification during installation and due to negligence of users during regular maintenance.

The development of mud brick stove by Research Center for Applied Science and Technology, Nepal (RECAST) in early nineties, which could be built on site in users households, by trained self employed workers (Promoters) with locally available materials gave the stove program a new look. The collective efforts of over 25 such organizations together promoted about 40,000 improved stoves of various types (mud, metallic) in different districts of Nepal.

3.1.1.4 Stoves for Using Honeycomb/Beehive Briquettes

For burning honeycomb/ beehive biomass briquettes specially designed stoves are required, which could either be made of metal or clay. In India normally metal stove with provision of using two honeycomb/beehive briquettes are used as shown in pictures.



Honeycomb briquettes used



Observations on the current



In Nepal both metal stoves as well as clay stoves are used, as can accommodate one briquette of ½ kg inside the combustion chamber of the stoves. The two models of biomass briquettes stoves, one made of metal and the second one of clay, are designed specifically to burn single honeycomb/ beehive briquettes at a time. Because charcoal is frequently used for barbecues and by restaurants requiring large heat capacity for cooking or grills, in Nepal a metal barbecue stand has been developed in which up to 8 honeycomb/ beehive biomass briquettes could be placed. Ventilation holes are provided in the bottom, through which the briquettes could be fired.

List of production items used in Nepal for making biomass honeycomb/beehive briquettes and the estimated cost in Nepalese Rupee (NR) and equivalent Indian Rupee (INR) are given in Table.3.1.

Table.3.1

Items required for production and utilisation of biomass honeycomb/ beehive briquettes	Specifications	Nepalese Rupees (NR)	Indian Rupees (INR)
Weed harvesting tools	Axes, hoes	300	180
Charring drum, 200 litre	3 mm sheet metal, 4 pieces	12,000	7,200
Grinder	Metal, rotating	10,000	6,000
Dust masks	Cotton/cloth filters	150	96
Mould, 19 pins, three piece	5" diameter and 4" high	5,000	3,000
Barbeque	8 briquettes	4,000	2,400
Thongs for briquettes	To fit into holes	30	18
Thick metal stove	One briquette, lined	400	240
Thin metal stove	One briquette, lined	300	180
Clay stove, three piece	One briquette, double wall	400	240
Tibetan stove	3 Briquettes, double wall	300	180
Briquettes, hand compacted	½ kg with Banmara	5	3
Compacting machine	1000 kg, pedal operated	25,000	15,000
Briquettes, press compacted	0,6 kg with Banmara	10	6
Transport container	To be designed		

Note: 1 NR = 0.6 INR

Based on the feedback, brief information about the promotional aspects of beehive briquettes stoves, in Nepal and India, as well as the comparative observations are summarized below:

- The honey comb briquettes are round with about 5" (12.5 cm) diameter and 3" (7.5 cm) height.
- The stove is locally manufactured by small-scale metal workshops or local blacksmiths commonly using recycled sheet steel.
- The Nepali stove allows only one briquette whereas the Indian stoves have provision for burning two briquettes at a time.
- When used for cooking, if stove doesn't have a fire shield around pot, cooking efficiency goes down.
- If the corners of briquettes get crumbles during handling, it will be due to higher percentage of soil in the briquettes, as well as insufficient compacting/ binding during production.
- High soil content, it results in producing large quantities of ashes while burning the briquettes.



Portable single honeycomb biomass briquette stove from which the insulation has been removed (above) and baked clay stove (below)

Simple or clear information about the briquette and the briquette stoves are required, backed by the awareness, motivation and education of the end users to ensure wider acceptance of honeycomb briquettes in rural areas of the country.

3.1.2 Biogas Technology

Biogas plant is an airtight container that facilitates fermentation of material under anaerobic condition. Other names given to this device are 'Biogas Digester', 'Biogas Reactor', 'Methane Generator' and 'Methane Reactor'. Recycling and treatment of organic wastes (biodegradable material) through anaerobic digestion (fermentation) technology not only provides biogas as a clean and convenient fuel but also an excellent and enriched bio-manure.

Thus the BGP also acts as mini bio-fertilizer factory; hence some people refer it as 'Biogas fertilizer plant' or 'Bio-manure plant'. For example, in a semi-continuous BGP, the fresh organic material (in homogenous slurry form) is fed into the plant from one end known as 'inlet pipe' or 'inlet tank'. Decomposition (fermentation) takes place inside the digester as a result of bacterial (microbial) action, which produces biogas and organic fertilizer (manure) rich in humus and other nutrients. There is a provision for storing biogas on the upper portion of the BGP. Some BGP designs have floating gasholder while others have fixed gas storage chamber. On the other end of the digester 'outlet pipe' or 'outlet tank' is provided for the automatic discharge of the liquid digested manure.



Domestic biogas plants installed in India and other South Asian countries use bovine (cattle or/and buffalo) dung mixed with equal quantity of water to maintain 8- 12% (average 10%) total solids (TS) concentration in the influent slurry. Whereas, the effluent has 9.5- 9.75% TS (average) discharged from the plants is, in general, collected into the slurry pits or spread onto the ground for drying before transportation to fields for use as organic manure.

Anaerobic digestion of organic matter produces a mixture of methane (CH₄) and carbon dioxide (CO₂) gas that can be used as a fuel for cooking, lighting, mechanical power and the generation of electricity, or a replacement for other fuels. Waste from the kitchen, human and animal waste, indigenous plants or residues from agriculture crops can be used for the production of biogas.

Applications:

- Replacement of firewood as the main fuel for cooking. It may also be used for direct lighting using especially designed biogas lamps, where there is no electricity.
- Generation of electricity using internal combustion engines or gas turbines.

Advantages:

- As a replacement for firewood the biogas reduces pressure on forests, and can aid to re-forestation projects.
- Biogas provides safe and environmentally sound way to dispose off a variety of organic wastes, thereby improving local health and sanitation.
- Solid residues from biogas production can be used in compost making.

Disadvantages:

- The system (especially batch-fed digesters) must be maintained and cleaned regularly with periodic removal of solid residues.
- Usual safety precautions must be observed for any gas distribution system.



A household digester unit or family size biogas plant normally has the gas production capacity to meet all the cooking and 2-4 hours of lighting (using biogas lamps with single mental) needs of a family. In India 1 m³ biogas plant refers to the rated capacity of that particular unit which has been designed to produce 1 m³, 1000 lt. or 35 ft³ gas per day under optimal conditions.

Table-3.2

Capacity, daily requirements of cattle dung and biogas produced, average cost of fixed dome biogas plant in India

SL. No	Plant Capacity		Av. Daily Fresh Bovine Dung and Slurry (ratio of 1 Kg. Dung :1 Lt. Water) Requirement		Approx. No. of Av. Size Cattle	No. of family members (cooking and lighting requirement)	Average cost as on Sept 1, 2006
	(M ³)	(Ft ³)	Fresh dung (Kg)	Fresh Slurry (Lt.)			
(a)	(b)	(c)	(d)	(e)	(f)	(g)	(Indian Rs.)
1	1	35	25	50	2-3	3-4	10000
2	2	70	50	100	4-6	6-8	12000
3	3	105	75	150	6-9	9-12	15000
4	4	140	100	200	8-12	12-16	18000
5	6	210	150	300	12-18	18-24	24000

Smallest size BGP having 1 m³ capacity can meet the cooking and lighting needs of generally a small family of 3-4 members. Whereas, the biggest family size of 6-m³ capacity plant can fully meet domestic needs of a comparatively large joint family (18-24 members).

Capacity rating of biogas plant- Indian Vs Chinese & International Terms

It is very important to know how a biogas plant is rated in different countries, other wise the confusion may arise among the practitioners and implementers of biogas technologies, especially for new people entering in to this field. This aspect is clarified further in the subsequent paragraphs, by giving examples of two main countries (India and China) involved in the promotion and implementation of simple household biogas models, especially for rural applications.

In India, where the biogas is mainly generated using cattle manure (dung), the capacity of RHh or FSBG plants is defined as the quantity of biogas produced from it in a day (24 hours) and measured in terms of cubic meter (cum or m³) or liters (lt.) or cubic feet (cft or ft³). Thus, in India a 1 m³ biogas plant refers to the rated capacity of that particular unit which has been designed to produce (generate) 1 m³ (or 1000 lt. or 35 ft³) per day (24 hours) under optimum conditions. This daily biogas generation is the average quantity of biogas, worked out on the basis of annual gas production data for a given temperature zone and corresponding HRT (and does not relate to either the maximum or minimum biogas production on any season or a given day).

Similarly, 2, 3, 4 & 6 m³ (cum), and so on implies that these biogas units have the rated (designed) capacity to generate an average daily production of 2 m³, 3 m³, 4 m³ and 6 m³ biogas per day etc., respectively, and so on, under optimum conditions. This is by and large accepted by individual and groups involved in the development, promotion, financing including the end users (rural people) of BGPs in India.

In China, the size (capacity) of biogas units is commonly referred in terms of digester volume. This is most appropriate as the Chinese use different types of crop wastes and green biomass etc. available in the season. They also use combination (mixture) of crop residues, which are not likely to give uniform gas production. Therefore, in China it is more logical to refer the capacity of biogas units in terms of digester (fermentation chamber) volume.

These two examples from India and China point out that one has to be careful in talking (referring) about the capacities of biogas units as it can cause lots of confusion.

As far as, the capacities of biogas plants are concerned, the most appropriate (and perhaps the most scientific too) way would be to refer the capacity of plant in terms of digester volume. The reason for this is that the volume of a given digester is always fixed but even for animal manure and night soil, the average biogas production [in a simple rural house-hold (family size) unit] always varies and have rarely found to be close to the rated (designed) capacity. The rural peasants in South Asian countries, operate their plants under varied field conditions and most of the times do not follow even some of the simple norms for plant operation on day-to-day basis, hence there is always a variation in biogas production as compared to its rated (designed) capacity, hence there is a case to redefine the norm for common International term for referring capacity of biogas plant, to be followed by all the countries.

Components of a simple household biogas plant (BGP)

Indian Semi-continuous-flow hydraulic digester household biogas plants are the most popular and common biogas plants built in rural India, which are floating gasholder model (KVIC) and fixed dome model (e.g. Janata and Deenbandhu model). So, the major components of only SCFHD biogas plants are: (i) Digester, (ii) Gas-holder or Gas storage chamber, (iii) Inlet, (iv) Outlet, (v) Mixing tank, and (vi) Gas outlet pipe.



3.1.2.1 Floating Gas Holder Biogas Plant

This is one of the common designs in India and comes under the category of semi-continuous-fed plant. It has a cylindrical shaped floating biogas holder on top of the well-shaped digester. As the biogas is produced in the digester, it rises vertically and gets accumulated and stored in the biogas holder at a constant pressure of 8-10 cm of water column. The biogas holder is normally designed to store 50% of the daily gas production.

3.1.2.2 Fixed Dome Biogas Plant

The plants based on 'Fixed Dome' concept was developed in India in the middle of 1970 after a team of officers visited China. The Chinese fixed dome plants use seasonal crop wastes as the major feedstock for feeding; therefore, their design is based on principle of 'semi-batch-fed digester'. The Indian fixed dome plant designs use the principle of displacement of slurry inside the digester for storage of biogas in the fixed 'Gas Storage Chamber'. Indian fixed dome BGPs are designed for pressure inside the plant varying from a minimum of 0 to a maximum of 90 cm of water column. The discharge opening is located on outer wall surface of the outlet displacement chamber and it spontaneously controls the maximum pressure.



3.1.2.3 Flexible Bag Biogas Plant

Main Unit of the Plant (MUP) including the digester is fabricated by using rubber, high strength plastic, neoprene or red mud plastic. The inlet and outlet are made of heavy duty PVC tube. A small pipe of same PVC tube is fixed on top of the plant as Gas Outlet Pipe. Flexible bag biogas plant is portable and can easily be erected. It requires support from outside, up to the slurry level, to maintain the shape as per its design configuration, which is done by placing the bag inside a pit dug on site. The depth of the pit should in proportion to height of the digester so that the mark of the initial slurry level is in line with the ground level. The outlet pipe is fixed in such a way that its outlet opening is also in line with the ground level. Some weight has to be added on the top of the bag to build the desired pressure to convey the generated gas to the point of utilization. Advantage of flexible bag plant is that the fabrication can be centralized for mass production. Individuals or agencies having land and basic infrastructure can take up fabrication of this BGP with small investment after some training. However, as the cost of good quality plastic and rubber is high. Moreover, the working life of this plant is also much less compared to other Indian household BGPs.

There are other plants available in India but are not very popular as Tunnel Shaped Biogas Plant and Split Design Biogas Plant (With Separate Gas Holder).

3.1.3 Solar Cookers

Solar cooker is one of the early devices developed. A box type solar cooker consisted of an insulated box with a glass cover and a top lid, which has a mirror on its inner side to reflect sunlight into the box when the lid is kept open. The inner part of the box is painted black. Usually 4 black painted vessels are placed inside the box along with the material to be cooked. The temperature of the blackened plate inside the box increases and it can heat up the space inside to 140°C. The cooking time is about 1½ hour to 3 hours depending on the items being cooked and the intensity of solar radiation. Since the cooking inside cooker is slow, the food cooked in it retains the nutrients better than that cooked in the conventional devices. Besides cooking the meals, the solar cooker can be used to prepare simple cakes and to roast groundnut, cashew nuts, 'papads' and dried grapes, etc. It, however, cannot be used for preparing 'chapatties' or for frying purposes.



A normal box cooker of 0.6m x 0.6m size having a weight of around 12 kg is capable of cooking 2 kg of food at a time, and it can save 3-4 LPG cylinders a year if used regularly.

Sun provides hot meals to 1000 devotees every day

Eco Centre ICNEER has installed a community solar cooker in the premises of World Renewal Spiritual Trust at Mount Abu in Rajasthan, India. Twenty-four parabolic dishes in two parallel rows with the dishes facing each other converge (direct in a small area) the Sun's rays onto water bearing pipes for producing 600 kg of steam at 200 °C at 16-20 bar. This steam passes through the kitchen where it is used to cook between 160-2000 meals each day. Mount Abu project is unique in the sense that it cooks meals for 1000 people at a time. Overall cost of the cooker was US \$ 30,000.

Solar Cooking in India is not new. Ministry of Non-Conventional Energy Sources (MNES), Government of India, launched a Solar Cooking Subsidy Scheme in the early 1980s to promote the use of solar cooker throughout the country. In 1994, MNES withdrew the subsidy on solar cooker but grants are provided to the state Renewable Energy Agencies to cover the cost of education and publicity. Till the date, total 5,41,000 box solar cookers, 630 concentrating solar cookers and 6 solar steam cooking systems have been sold/installed.

At one stage there were around 60 manufacturers of box type solar cookers in India and the cookers were being sold through 375 sales outlets in most states. Over 400,000 box type solar cookers have already been sold in India. Similarly, concentrating-type (Parabolic-SK-14) solar cookers are being used in India to cook Mid-Day meals for pre-school children (Balwadies) by some NGO members of INSEDA, like WAFD in India. The Parabolic-Solar cookers (SK-14) are also being promoted other South Asian countries.

Various types of solar cookers such as dish solar cookers to prepare food for 10-15 people outside the kitchen, indoor type solar cooker to cook food for around 50 people and solar steam cooking systems to cook food for 1000 people, are being installed in community kitchens of roadside dhabas (restaurants), ashrams, boarding schools, religious places. It uses a lens or a reflector suitably designed to concentrate the solar radiation over a small area. This cooker is able to provide higher temperatures on its absorbing surface when suitably designed.

A community cooker and a dish solar cooker when used regularly can save 35 and 10 LPG cylinders per year, respectively. Seeing the performance of the world's largest solar steam cooking system at Taleti, Mount Abu, installed in 1999-2000 for 10,000 people, a solar steam cooking system based on similar technology is now operating in several institutions in India

3.1.3.1 Box Type Solar Cooker

Important parts of a solar cooker include the outer box with thermal insulator, inner cooking box or tray, the double glass lid, mirror and cooking containers. The outer box is generally made of GI, aluminum sheet or fibre reinforced plastic. Inner cooking box or tray is made up of aluminum sheet coated with black paint to absorb solar radiation and to transfer the heat to the cooking pots. Cooking tray is covered with a double glass lid in which two glass sheets are spaced at about 20 mm to capture air. It acts as insulator and prevents escape of heat from the inside. The space between the outer box and inner tray including



bottom of the tray is packed with insulating material such as glass wool pads to reduce heat losses from the cooker. In addition to above, the cooker is fitted with a mirror to increase the radiation input on the absorbing space. This radiation is in addition to the radiation entering the box directly and helps to quicken the cooking process by raising inside temperature of the cooker. The cooking containers (with cover) are generally made of aluminum and painted black on the outer surface so that they also absorb solar radiation directly. A large number of items such as pulses, rice, kheer (rice pudding), khichri (mixture of pulse and rice), vegetables, meat, fish, etc. can be cooked in the solar cooker. The time taken to cook depends upon type of food, angle of the sun and solar intensity.

3.1.3.2 Solar Baking Unit

Solar baking unit is a scaled up version of double reflector box type solar cooler. It is designed to generate higher stagnant temperatures required for baking.



In order to increase the solar radiation entering the hot box, additional reflectors have been incorporated to reduce the cooking time. In this cooker, twin reflector mirrors (unbreakable acrylic mirror) are fixed. It is effective in central and north India especially in winter season. It is useful for cooking food and baking. As compared to box solar cooker with one mirror, the twin reflector solar baking unit maintains 25 to 30 °C temperature. It saves 20% and 12-16% of time, respectively, spent in cooking food during winter and other months. It has thermostat controlled electrical back up of 1 kW to enable proper baking continued even when sudden clouds appear in sky. It is also suitable as a community cooker for up to 10 persons.

3.1.3.3 Community Solar Cooker

Community Solar Cooker (Rotating Disc Type) works on the principle of solar energy concentration using a Reflecting Parabolic Solar Concentrator. It consists of 7-m² parabolic solar concentrator. Solar Concentrating Disc or Primary Reflector) is used for concentrating solar radiation on a focal area where cooking vessel is placed. With the help of simple automatic mechanical tracking system the solar disc rotates with the movement of Sun to give continuous and accurate solar energy concentration. This mechanical device is made up of a simple clock mechanism with chain and gear arrangement to provide regulated tracking motion to follow the path of the Sun throughout the day. It works for 6–8 hours in a day. The Secondary Reflector is provided in the north-facing wall of the kitchen or cooking place just below the cooking vessel. This reflector receives the concentrated solar radiation and reflects it on to the bottom of the cooking vessel as shown in the figure. The Solar Cooker is installed in the open shadow-free area or on terrace tops facing the South. The reflection of the disc falls on a secondary reflector housed in an opening in the North kitchen wall. The secondary reflector further reflects radiation on to the cooking vessel. The Solar Disc is installed in an open area- terrace or courtyard- facing the South. The cooker is very simple to operate and easy to maintain. Daily in the morning, the disc is manually oriented so as to face the morning sun. Daily orientation action winds the clock mechanism to work throughout the day and the disc starts rotating in direction of the Sun guided by Sundial. The Cooker begins to work automatically as the concentrated solar energy is directed to the cooking vessel. Yet, the seasonal orientation (adjustment) of the disc is required to be done once in six months due to shift in Sun's position with respect to the Earth axis.

3.1.3.4 Community Solar Cooker (Scheffler)

The solar cooker developed by Mr. W. Scheffler, ULOG Group of Switzerland, has the advantage of cooking food inside the kitchen itself. This is the latest among community solar cooker designs. Its special features are as follows:

- A parabolic dish that reflects sunlight into the kitchen and then onto a secondary reflector located below specially designed cooker.
- The cooker's temperature can be regulated as easily as in conventional cooking.



- The cooker's temperature can be regulated as easily as in conventional cooking.
- It can be used to boil, fry and bake.
- Unlike other parabolic dishes, this one is flexible with a curvature that can be adjusted seasonally.
- Maximum temperature it creates is 450 °C.
- It has cooking capacity of 70–80 meals per day requiring 1–12 hours to prepare each dish.

3.1.4 Charcoal and Briquetting

Charring and briquetting technologies reduce many problems associated with management and utilization of biomass in domestic and industrial sectors. Briquetting of some of crop residues has become cost effective and it is considered as the replacement of firewood in India.

Biomass is widely used for heat and power generation with the latest combustion and gasification technologies. Same combustion technologies can be used to burn domestic and commercial waste to obtain energy, which can present opportunities for improved waste management strategies.

The raw materials needed for making briquettes include biomass derived from agricultural residue and forest products, shrubs, pieces of fuel wood trees, saw dust, etc. and sticky clay soil as binder. When briquettes are produced using charring drum, funnel is inverted first inside the drum; dried materials are then spread over funnel and burnt. As the dried biomass materials start burning a little, dried materials are continued to add and burn. Raw materials should not be burnt completely. Chimney is attached to the top of the inverted funnel through which white smoke is ejected. The process of semi burning of biomass is done layer by layer until the drum is filled two-third. Then the chimney is taken out and drum is covered and water-sealed to completely extinguish the fire. Once the fire is extinguished and cooled down then the coal is taken out, pounded into powder, mixed with the binding sticky clay soil with water all in appropriate ratio (3 parts of coal: 1 part of binding clay soil). Then the well-mixed coal is put in the briquette mould and compressed well with hand or machine. The briquette is then taken out and dried for 2-3 days under the sun. While drying, briquettes should be kept on plane and hard surface and should be covered with plastic during the night to protect from rain and wind. Once the briquette is dried and made hard, it is ready for burning in the briquette stove. When produced manually, one person can make about 30 round beehive briquettes with 19 holes through which blue fire-flame comes out when burnt. Depending on the quality of briquettes, one beehive briquette burns for an hour to two and half hour. If the semi-burnt charcoal is machine pressed, it results better fire efficiency. Cost of the briquette piece ranges from 10-20 rupees (15-30 cents). A normal meal for a nucleus family of 4-5 members can be cooked with one briquette.

Applications:

- Biomass briquettes are prominently used in domestic cooking and heating.
- Centralized power plants based on biomass combustion, pyrolysis or gasification can provide electricity and heat with generation capacities ranging from hundreds of kW to hundreds of MW.

Advantages:

- Availability is abundant.
- Can be used to burn waste products.
- Continuous planned growing of energy crops absorbs CO₂ at same rate as it is produced in the combustion process, thus leading to no net increase in atmospheric CO₂.
- Organized tree planting contributes to water management, reduction of heat in arid areas and in prevention of desertification.
- Reforestation schemes improve soil conditions and prevent severe floods etc.
- Easy to convert to high energy portable fuel (e.g. gas).
- Comparatively cheap.

Disadvantages:

- Needs a large area of land with high initial cost of building power stations.
- Burning biomass can result in air-pollution, if not planned properly.

3.1.4.1 Portable Charring Kiln

Portable charring kiln is a simple unit for converting agricultural residues to a charred mass. It consists of a M.S. drum, handle and door. Due to its cylindrical shape, it can be rolled easily to the site of use. Waste agricultural mass such as soybean straw, pigeon pea stalks, cotton stalks and other material can be used. A small quantity of residues is fed into the kiln and ignited. When it gives a white smoke and starts to burn properly, additional material is added to the kiln. By continuing the process, whole of the kiln gets filled. Cover is then closed and the hot mass is allowed to pyrolysis. After 6-8 hours, the unit cools down and the charred mass can be emptied. The char obtained is used for making smoke free kitchen fuel by converting them into briquettes.

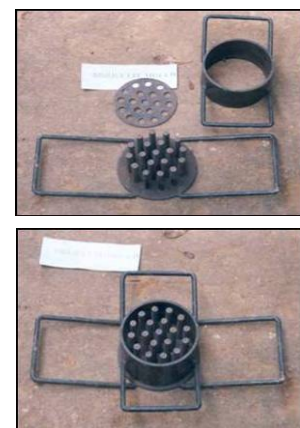

The mould for making honeycomb/Beehive

3.1.4.2 Honeycomb/Beehive Briquettes

The honeycomb/bee hive shaped biomass briquettes is made by using hand mould and it is so simple that it can be fabricated/manufactured by local blacksmiths in rural areas. This hand mould (for honeycomb/bee hive briquettes) consists of 3 parts and is manufactured by local blacksmiths from thick steel plate (5 mm) and smooth iron concrete reinforcement bars (12 mm). The mould is 90 mm high and has an internal diameter of 5" (127 mm). 19 holes of 12.5 mm (½ inch) in the bottom allow easy lifting of the pins and briquette out of the mould. Handles are 10 mm thick. This mould costs NR (Nepalese Rupees) 5,000 or INR (Indian Rupees) 2,000. Hand moulding requires 5 kg metal; however, it does not produce a high briquette density. Estimated moulding pressure may vary between 2-3 kg/cm². One person can make 30 briquettes per hour with hand moulding provided the charcoal-clay mix/paste is ready.

During the manufacturing of new moulds it is recommended to use a precise welding jig for 19 pins and a drilling jig for the holes. This way the perforated plate can be placed in any position over 19 pins¹. The weight of hand-made, dried briquette is about ½ kg. Average production cost of dried honeycomb briquettes in Nepal is NRs. 2.50-3.00 per piece, whereas the briquettes market price is NRs. 4.00 per piece. Local cost of pure charcoal used by blacksmiths is about NRs. 8.00 per kg.

Calorie Value: Pure woody biomass charcoal produces about 28 mega Joule/kg. Well-compacted, dried briquette has a weight of about ½ kg. At high altitudes the briquettes should be adequately dry, while at lower altitudes it may contain humidity by 15 % or more. Hardwood biomass charcoal briquettes with 20% clay content produce about 18 MJ/kg or about 9 MJ/briquette. In practice this may heat 2 litres of water in 15-20 minutes using the insulated (one briquette) metal stove (from about 20-98 °C at 1300 m altitude). Burning duration of this briquette is about 1.5 hour.

Forest and agricultural waste charcoal briquettes, also with 20% clay, produce about 12 MJ/kg or 6 MJ/briquette depending on the composition of charcoal. In practice, this may heat 2 litres of water in 30-45 minutes by using the single briquette stove. Burning period of 1 briquette is about 1 hour.

3.1.4.3 Low Cost Briquetting Machine

The briquetting machine designed for converting charred biomass into cylindrical briquettes is a screw type extruder unit. It has a hopper for feeding the char and cow dung mixed to predetermined proportion of water. Feeding is done slowly. Outlet end has a number of openings forming the die through which the briquettes come out continuously. These are collected separately in trays and left in the sun for drying. The larger unit is operated with 2.25 KW motor and produces 60-75 kg of briquettes per hour. The smaller version produces about 40 kg of briquettes per hour.



3.1.5 Hay Box Cooker

It is a simple well-insulated box lined with a reflective material into which a pot of food is placed. Food is cooked in 3-6 hours by the heat retained in the insulated box. The insulation greatly slows the loss of conductive heat. Convective heat in the surrounding air is trapped inside the box and the shiny lining reflects the radiant heat back into the pot. Simple hay box cookers could be introduced along with fuel saving cook stoves in areas where slow cooking is practiced. How these boxes should be made, and from what materials, is perhaps best left to people belonging to different regions. Ideally, the hay box cooker should be made of inexpensive and locally available materials and should have standard pot sizes used in the local area.

Instructions for building Hay Box Cooker

- a) Insulation should cover six sides of the box, especially the bottom and lid. The box should be perfectly airtight. Improper insulation may result the loss of heat.

¹ The non-precise positioning of the 19 pins (in a star pattern) on the mould base would allow the base plate to be fitted in only one position.



- b) Inner surfaces of the box should be of a heat reflective material, such as aluminum foil, to reflect back the radiant heat from the pot.
- c) A simple, lightweight hay box can be made from 60 x 120 cm sheet of rigid foil-faced insulation and aluminum tape.
- d) Hay box cookers can also be constructed as box-inside-a-box with the intervening space filled with a good insulating material. Required thickness of the insulation will vary based on the efficiency of the insulating material.
- e) Some of the good insulating materials, suitable for 'Hay Box Cooker', with suggested wall thickness are given in Table.3.2.
- f) Box can be made of wood, cardboard or any combination, but the lid should be airtight.

Instruction for Using Hay Box

- a) Cooking with Hay Box Cooker requires some adjustments as given below:
 - (i) Less water should be used since it is not boiled away,
 - (ii) Less spicing is needed since the aroma is not boiled away, and
 - (iii) Cooking must be started earlier to give enough time to the food to be cooked at lower temperature than over a stove.
- b) Hay box cookers work best for large quantities of food, as small amounts of food have less thermal mass and cool faster comparatively. Combination of two or more smaller amounts of food may be placed in the box to cook simultaneously. Food should boil for several minutes before placing in the box. This ensures that all the food is at boiling temperature, and not just the water.
- c) The hay boxes perform best at low altitudes where boiling temperature is highest. They should not be expected to perform well at high altitudes. One great advantage of hay box cookers is that the cook no longer has to keep the fire burning, watch or stir the pot once it is in the box. In fact, the box should not be opened during cooking, as valuable heat is lost.

3.2 Electrical and Mechanical Devices

There is direct correlation in energy consumption and economic status of a country or region. The energy for economic activities has to be in a form to provide mechanical output, which can be used for production of certain items. As most of the production units use electrical energy, several systems have been developed to harness sustainable energy from sun, water, biomass, and wind. Some of the sustainable energy technologies developed to produce electricity have matured and several modules of these are available in the market, such as solar photovoltaic systems, micro-hydro, biomass based power generation systems, and windmills. Some of these technologies such as windmills can also be used directly for mechanical output without converting it into electrical energy. Under each type of sustainable energy, some selected technologies, which are suitable for small households for economic up-liftment or simply for their household needs are described here.

Considerable work has been done by research institutions to harness the sustainable energy in the form of animal and human power that is grouped under broad category of "animate energy". Apart from agricultural work, animate energy has been traditionally used for various mechanical outputs such as for threshing, grinding, oil expelling, drawing water, etc. However, systems to harness animal power for electricity generation have not been matured as yet and require lot more work. Treadle pump, which utilizes human power efficiently for pumping water from shallow wells, has been popular in Bangladesh and some parts of India, in Gangatic belt.

The electrical form of energy is also important for education, entertainment and other household cores apart from economic point of view. However, a large population is either completely deprived of this in South Asian villages or receive irregular supply of the same. It is therefore necessary to not only strive for producing electricity but also ensure electricity conservation in urban areas. Some of the electricity conservation tips have also been mentioned in this section.

3.2.1 Solar Photovoltaic Systems

In solar photovoltaic (SPV) technology, the solar radiation falling on a device called solar cell is converted directly into electricity without any environmental pollution.



Photovoltaic (PV) or solar cells as they are often referred to are semiconductor devices that convert sunlight into direct current (DC) electricity. Groups of PV cells are electrically configured into modules and arrays that can be used to charge batteries, operate motors, and to power any number of electrical loads.

With the appropriate power conversion equipment, PV systems can produce alternating current (AC) compatible with any conventional appliances, and operate in parallel with and interconnected to the utility grid.

Although a PV array produces power when exposed to sunlight, a number of other components are required to properly conduct, control, convert, distribute, and store the energy produced by the array.

Depending on the functional and operational requirements of the system, the specific components required, and may include major components such as a DC-AC power inverter, battery bank, system and battery controller, auxiliary energy sources and sometimes the specified electrical load (appliances). In addition, an assortment of balance of system (BOS) hardware, including wiring, over current, surge protection and disconnect devices, and other power processing equipment.



SPV pumping systems are ideal for lifting water for drinking and irrigation without harming the environment. These pumps can be installed in boreholes, tanks, cisterns or rivers. DC surface pumps are designed for high flow rates at low heads. DC floating pumps are suitable for wide range of flow and head situations.

Applications:

- Telecommunications: to power satellites, remote transmitting stations, radio and TV sets, and telephone booths.
- Transport applications: to power car parking meters, automatic lawn movers, boats, future electric vehicles and in car parks with solar charging trees.
- Refrigeration: to power refrigerators in remote hospitals and health centres, mobile refrigerators to transport blood samples and medicine in desert areas, ice cream carts, etc.
- Lighting: to provide street lighting, standalone home lighting systems, and to charge solar powered lanterns.
- Water pumping: to provide clean water for drinking and washing, water for fish farming, animal farming, drip irrigation and large scale irrigation systems. This method of irrigation is ideal for cultivation of arid zones next to deserts for food production, and tree plantations in order to prevent desertification.
- Large-scale power generation: through connecting solar roofs and solar farms to the national grid.

Benefits:

- Free and unlimited supply of power for basic requirements such as lighting and the use of radio and television in remote areas. This improves the quality of life.
- Better lighting systems increase opportunities for education and income generation activities, and it may enable schools and businesses to access computer facilities in non-electrified villages.
- Helps in pumping water for drinking, irrigation, washing and fish farming, thereby increasing the production of food.
- The large-scale power generation using solar farms and solar roofs will feed the national grid without CO₂ emission. This energy can be used for industry and other applications during the daytime saving fossil fuels or water in reservoirs.
- The use of freely available solar energy to produce hydrogen from freely available water as a clean fuel of the future.



Disadvantages:

- Reliability depends on sunlight; back up is, therefore, necessary.
- Energy is available during daytime only, and thus storage facilities are required for many applications.
- Costs need to be further reduced via scientific research and development for rapid market penetration, although photovoltaic technologies are already economically viable for remote and standalone applications.
- Recycling facilities should be established in order to prevent any contamination from toxic elements in batteries and other solar equipments.

3.2.1.1 Solar Lantern

A Solar Photovoltaic Lantern is a lighting system consisting of a lamp battery and electronics all placed in a suitable housing made of metal, plastic or fiberglass and a PV module. The battery is charged by electricity generated through the PV module. The lantern is basically a portable lighting device suitable for either indoor or outdoor lighting covering a full range of 360 degrees. A lighting device that provides only unidirectional lighting will not be classified as a solar lantern in the present context.

A Solar lantern is a simple application of solar photovoltaic technology, which has found good acceptance in rural regions where the power supply is irregular and scarce. Even in the urban areas people prefer a solar lantern as an alternative during power cuts because of its simple mechanism. It is made of three main components: the solar PV panel, the storage battery and the lamp. The operation is very simple. The solar energy is converted into electrical energy by the SPV panel and stored in a sealed maintenance-free battery for later use during the night hours. A single charge can operate the lamp for about 4-5 hours.

The solar lantern should provide a minimum of 3 hours of lighting per day under average daily solar radiation conditions of 5 kWh/m² on a horizontal surface. Solar panel is guaranteed to work for 15 years without any trouble. The actual duration of lighting may vary depending on the location, season, etc. Average costs of the solar lantern vary from Rs. 4500 to Rs. 7500.

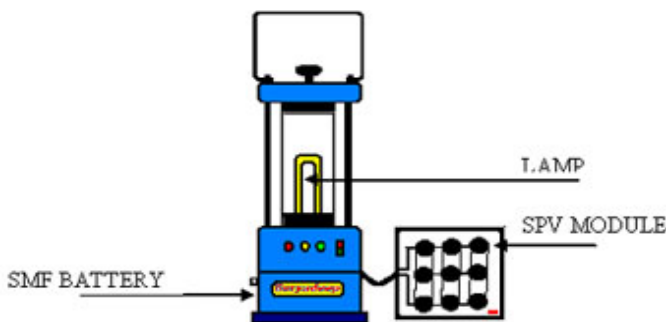

The solar lantern consists of a small photovoltaic panel to capture and convert sunlight into direct current (DC). The DC is used to charge a sealed maintenance free acid battery using a charge controller. Whenever light is required the DC is inverted and fed to a compact florescent lamp of 7-9 Watt rating.

3.2.1.2 Solar Home Systems (SHSs)

Solar home systems (SHS) are a popular use of solar energy. A solar PV module and a battery provide basic electricity for single households. The module is typically between 20 Watt and 100 Watt and the battery between 30 and 150 Ah. In addition a charge controller and DC low voltage wiring is needed. The electricity is used for light, radio, small TV, charging of mobile phones and small batteries, electric tools. Larger systems above 100 W can also power an efficient refrigerator.

Compared with electric grid systems, SHS are quicker to install, can be used almost everywhere, and are not plagued by power cuts. On the other hand the electricity is limited to the capacity of the panel and the battery, so the electricity has to be used with care and high-powered equipment cannot be used, or can only be used for a short time.



SHS are relatively expensive, and the electricity price is high compared with grid-based electricity, though much lower than the cost of electricity from dry batteries. If the grid is some distance away from a house group or a small village, often SHSs are cheaper than grid connections.

While a good PV panel can last for over 20 years, good batteries (tubular, lead-acid, deep-charge batteries) can be charged only 1200–2000 times, equal to 4–8 years of operation, and only if they are well maintained and not overheated. Cheap batteries and car batteries have short lifetime in solar installations, often less than a year. A few cheap PV panels, mostly of the amorphous type, have had short lifetimes of only 3-5 years, after which the electricity production was only half of the original production. Also the charge controller is a component that can fail, mostly if it is overheated. A failure of a charge controller can lead to destruction of the battery that it charges.



Because of the high costs of SHS some people have used one SHS for both a family and a shop, or for two families. Also income generation activities are often combined with investment in a SHS, such as working in the electric light at night or selling power from the SHS to charge mobile phones.

This system has a battery large enough for a few cloudy days, and can give light for 4 hours/day. Some systems have smaller batteries and can only store the electricity from day to night.

3.2.1.3 Solar Street Light

Solar streetlight consists of two photovoltaic models of 36 Watts each mounted on a 6 m lamppost for charging. At the base of pole a box is provided which houses the charging system, a storage battery and inverter unit. The unit is also provided with light sensitive switch so that the street lamp gets lighted after sunset. The panel captures sunlight during daytime and stores in battery by using a charge controller.

3.2.1.4 Solar Pump

A solar photovoltaic water pumping system consists of a photovoltaic array mounted on a stand, and one of the following motor-pump sets compatible with the photovoltaic array. The photovoltaic array converts the solar energy into electricity, which is used for running the motor pump set. The pumping system draws water from the open well, bore well, stream, pond, canal.



The system components of solar photovoltaic water pumping system are: photovoltaic array, motor pump set, interface electronics, connecting cables and switches, support structure and tracking system, pipes, etc.



The SPV water pumping system is used in agriculture, horticulture, animal husbandry, poultry farming, high value crops, orchards, silviculture, fish culture, salt farming, drinking water, etc.

Water pumping systems are available in different types to meet various needs and applications:

- **Surface Pumps:** These pumps are suitable for lifting and pumping water from a maximum depth of 20 meters (total head).
- **Submersible Pumps:** These pumps can be used in areas where water is available at a greater depth and where open wells are not available. The maximum recommended depth of these systems could be 50 meters.
- **Solar Hand Pumps:** These pumps are exclusively designed by Balaji Industrial and Agricultural Castings to meet both the requirements of surface and submersible pumps. It has a manual operation mode where the system can be used manually once sufficient sunshine is not available to drive the pump.



Applications:

These pumps are used in village water supply, livestock watering, remote homes, micro-irrigation, homes, dispensaries and community centers, etc. A SPV water pumping system is available with a photovoltaic array of capacity in the range of 200 watts to 3000 watts (Capacity of motor pump set is from 0.5 hp to 2 hp).

The system is expected to deliver a minimum of 65,000 liters per day for a 900 watts panel and 135,000 liters per day for an 1800 watts panel from a suction head of 7 meters and/or a total head of 10 meters on a clear sunny day. In case of deep well submersible pumps, the water output shall be a minimum of 45,000 liters from 1200 hp. The SPV water pumping system may command an area of irrigation 0.5-6 hectares at a total head of 10 meters depending on water table, type of soil and water management. Table.3.2 indicates critical irrigation command area for different crops with the type of method used.

Subsidized cost of installation and commissioning of a SPV water pumping system will vary between Rs. 1,90,000 to Rs.2,70,000 depending upon the supplier and model. Subsidy available is of Rs.110 per hp subject to a maximum of Rs. 2,50,000 per pump set.

Solar PV modules have a long-lasting life of more than 20 years and are absolutely maintenance free according to Balaji Industrial and Agricultural Castings, who is one of the manufacturers.

Table.3.2

Critical command area in ha	S. No.	Crops	Irrigation method
1.00	1.	Year round vegetables cultivation	Surface
1.41	2.	Chillies/sorghum/groundnut	Surface
0.70	3.	Paddy nursery	Surface
2.08	4.	Garlic	Micro sprinkler
1.82	5.	Cucumber	Drip
1.97	6.	Groundnut	Micro sprinkler
2.14	7.	Grapes	Drip
4.89	8.	Lime	Drip
2.36	9.	Banana	Drip
7.32	10.	Pomegranate	Drip

3.2.1.5 Solar Tracking Device

Orienting a photovoltaic panel from the morning to evening to face the sun can increase its performance by up to 30%. The solar tracking device is designed to accurately track a solar panel fitted on a specially balanced frame. It has an electronic timer unit and a set of gears to transmit the power to the panel. Orientation is accomplished in small steps of 38 pulses per minute and its motion is almost imperceptible. Power for the tracking unit is obtained from one of the panels with a charge controller and small storage battery. At the end of the day, the frame closes a limit switch and the tracker is powered off. On the next day, the unit is disarrayed with the help of the clutch provided and oriented to face the sun. Thereafter, tracking takes place automatically for the whole day. Thus it needs attention only for a few minutes at the start of the day. Due to increased output, higher rating of load can be used with such panels.



3.2.1.6 Solar Photovoltaic Refrigerator

A solar photovoltaic refrigerator has been developed to keep vaccines, medicines and other perishables. A solar photovoltaic (SPV) panel of 180 Watt peak power along with a battery pack supplies the powers to the compressor unit. The unit is operated on direct current power supply and hence special compressor unit has been adopted. The unit has an opening on the top so that cold air doesn't escape when it is opened for removing/replacing the product.

3.2.2 Micro Hydro Systems

Micro hydropower is an indigenous and renewable source of energy for which the potential exists in almost the whole Hindu-kush Himalayan Region, which includes Afghanistan, Bhutan, China, India, Myanmar, Nepal and Pakistan. Micro Hydro (MH) is generally defined as decentralized small-scale water power plant less than 100 kW. Micro hydro can provide electricity to rural communities which otherwise might take years to be served by national electricity services.



Advantages

- The components of MH can be locally manufactured and systems can be locally assembled.
- The adverse environmental effects are minimal.
- MH Plants are comparatively easy to manufacture and install indigenously, thus boosting employment, economic activity and the industrial base.
- The MH systems can be locally managed, operated and main much lower trained with training input to the local people. The organization and management cost are lower than for the other energy systems.

The basic principle of hydropower is that if water can be piped down from a certain level, then the resulting water pressure is converted to work.

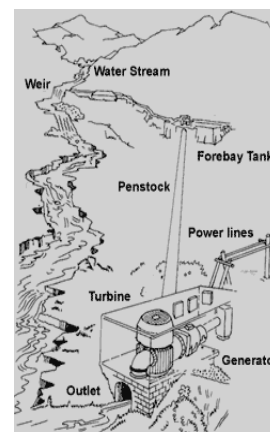

If the water pressure is allowed to move a mechanical component then that movement involves the conversion of the potential energy of the water into mechanical energy. Hydro turbines convert water pressure into mechanical shaft power, which can be used to drive an electricity generator, a grinding mill or some other useful device.

Various components of a micro hydro

Civil Components: Structures designed to conduct water from source to the turbine for optimum energy generation. It has several sub-components described below:

Turbines: The turbine converts energy from the falling water into rotating shaft power.

Drive System: Transmits power from the turbine shaft to the generator shaft or the shaft powering other devices. It also has the function of changing the rotational speed from the one shaft to another when the turbine speed differs from the required speed of the alternator or device.

Electrical Systems: Convert mechanical power into electric power. This consists of a generator and alternator.



The functional life of a micro hydro plant is considered to be 15 years. However, a lot depends on how the plant is maintained. Civil structures usually last for a long time, if they do not subject to natural calamities like folds and earthquakes. The life of electro mechanical components depends on the quality of the products installed and on how they are maintained. Regular preventive maintenance generally increases the lifetime of the equipment.

3.2.3 Biomass Based Power Generation

Biomass materials such as firewood and agro-residues essentially contain carbon, hydrogen, and oxygen along with some moisture and ash. Direct combustion of biomass is generally inefficient and smoky that cannot easily be controlled. About 200 million tonnes of firewood and equivalent amount of agricultural residues are burnt annually in India with end-use efficiency of approximately 10%. Under controlled conditions characterized by low oxygen supply and high temperatures, most of the biomass materials can be converted into gaseous fuel known as “producer gas”, which comprises carbon monoxide, hydrogen, carbon dioxide, methane and nitrogen.

This gas has a lower calorific value than natural gas or liquefied petroleum gas, but can be burnt with high efficiency and good degree of control without emitting smoke. The conversion efficiency of the gasification process is in the range of 60%–70%. Usage of gasifiers in place of conventional direct burning devices leads to savings of a minimum of 50% fuel.



For thermal applications, the technology has been well proven and gasifier systems are already working in the field. The capacity installed so far covers a wide range of applications at different capacities. It has range from 30 KW_(t) to 500 KW_(t).

Gasifier is essentially a chemical reactor where several thermo-chemical processes such as pyrolysis, combustion and reduction take place. Depending on the movement of gases relative to the fuel bed, various gasifier designs can be classified: updraft, downdraft and cross-draft gasifiers. Traditional downdraft gasifiers have throats or choke plates in order to reduce the tar content of the gases, but throatless designs are limited. Advanced designs such as fluidized bed systems, high-pressure gasifiers, or designs with tar recycling are yet to be perfected. Gasifier designs usually depend on type of fuel, moisture content, ash content, fuel pellet size, etc. Certain biomass fuels such as rice husk have the tendency to form slag at high temperatures, and hence may require different designs.

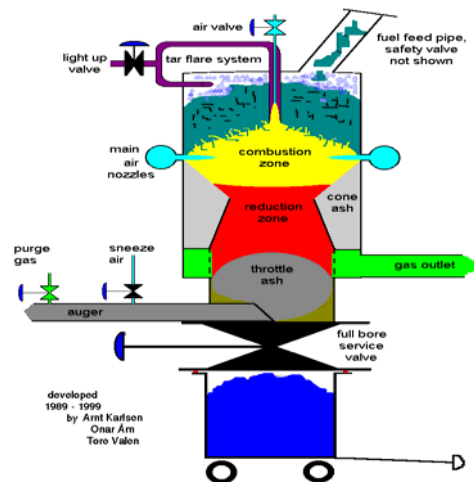

Advantages of Gasification

Conversion of solid biomass into combustible gas offers all the advantages associated with using gaseous and liquid fuels.

It is attributed to clean combustion, compact burning, high thermal efficiency and good degree of control. In locations where biomass is already available at reasonable low prices (e.g. rice mills, coffee/corn processing units, sugar mills, etc.) or in applications utilizing fuel-wood (e.g. institutional cooking, silk reeling units, etc), gasifier systems offer definite economic advantages.

Advantages of using producer gas

- Reduces firewood consumption by at least 50% in large stoves
- Saves LPG in large-scale cooking
- Saves LDO (light diesel oil) and furnace oil in boiler applications
- Replaces up to 80% of diesel oil in diesel generator sets operated in dual fuel mode.

Application of the technology: Steam generation

- Baby boiler is used at present in many small industries like food processing industries
- Boilers can be retrofitted easily to burn producer gas
- Installation of gasifier helps replace wood/ biomass burning boilers which are generally bulky, polluting
- Users of LDO and furnace oils can shift to firewood /wood waste briquettes at specific sites where biomass is available at low cost.

Institutional/large-scale cooking

- Fuel-wood is used in large quantities for cooking in hostels, hospitals, hotels, marriage parties, and sweet shops
- Thermal efficiency of large stoves using firewood is low (approx. 10%) and requires large quantities of firewood
- Use of gasifier reduces fuel-wood consumption by about 50%
- Power delivered can vary, thereby causing the cooking process faster
- Depending on availability of biomass and space LPG users can shift to firewood/biomass briquettes.

Silk reeling industry of South India

- Thermal efficiencies of cottage basin ovens are very low (10%–14%)
- Use of gasifiers can reduce firewood consumption by 50%
- Clean fuel gas obtained by burning producer gas can be used for drying of pupae (silkworm)
- Producer gas can also be used for stifling of cocoons to kill pupae.



3.2.4 Windmills for Electricity and Pumping

Windmills that use the wind for electricity generation is the fastest growing power supply in the world and India is among the world leaders in the development of large wind turbines for electric grids. For off-grid installations and pumping a number of smaller models exist.

For electricity production the most efficient and popular model is the one having three blades with horizontal axis. For water pumping, the multi bladed wind rose is most popular, as its slow rotation with a piston pump suits to the needs.

Applications:

- Domestic use: to provide power for homes and work in remote areas for lighting, radios, televisions, machines.
- Pumping for drinking water, irrigation and other purposes
- Large-scale power generation with connection to the grid.

Advantages:

- Power generation occurs whenever the wind is blowing, and can operate any time during the day or night.
- Land around the turbines may still be used for agricultural production.
- No air/water pollution.
- All the benefits mentioned in section 3.2.1 under photo-voltaics (PV) are applicable to wind energy; while mostly wind power is cheaper than power from PV.

Disadvantages/problems:

- Substantial initial costs.
- Success depends on a good site, in particular for larger turbines
- Generation may be intermittent and is best suited to sites with regular and reliable wind patterns, or in combination with other sources (see below).
- Complex rotating machinery requires regular servicing from trained personnel.
- Care must be taken to avoid noise from the turbines, e.g. by keeping a distance to houses.
- small windmills are not used widely in South Asia and are not always available.

A reliable windmill for electricity of 300 Watt can be bought for €1,000 (Rs. 50,000). In good wind conditions it can generate electricity of 600 KWh/year, with an average of 1.6 KWh/day. Often the windmill generates 2-3 times more electricity than PV panel, both of the same price.

Hand-rules for smaller wind turbines:

The wind increases with height and as a thumb rule a windmill hub (center of blades) should be 10 m above any obstacle within 100 m. Small windmills can be combined with a charge controller and batteries connected with PV system. Because of variations in wind a large battery bank is recommended, up to 7 days of consumption. Windmills can also be combined with PV or hydro. PV and hydro give more stable and daily supply, but PV have limitations because of higher costs and hydro with irregularity in water streams.

3.2.5 Animate Energy

Animate energy sources, derived from human beings and draught animals (for example, bullocks), account for the bulk of the energy used in agriculture particularly among small and marginal farmers. Apart for draft power, animate energy has been traditionally used for various mechanical outputs such as for threshing, grinding, oil expelling, drawing water etc. Systems to harness animal power for electricity generation are being developed at various research institutions but require lot more work. Treadle pump for pumping water from shallow wells, has been popular in Bangladesh and some parts of India, in Gangatic belt and is being described further.



Large windmills for power



Wind rose for pumping



Small windmill for electricity, 300 W. South West Wind power

3.2.5.1 Treadle Pump (Krishak Bandhu Pump- KBP)

In recent years, small and marginal farmers (especially the vegetable growers with 0.25 to 0.75 acre of lands) usually depend on either the inefficient and time-consuming manual operated irrigation devices or use the hired diesel engines from medium or big farmers for irrigation purposes. Due to unprecedented rising cost and unpredictable supply of diesel in rural and tribal areas in the last 2 years, as a result of the unprecedented global rise in the cost of crude oil (i.e. US \$ 70 per barrel), is affecting the agriculture output and the livelihood of such categories of farmers. Treadle Pump, a grassroots technology christened as “Krishak Bandhu pump-KBP” (meaning friend of the farmers) in India, is an ideal pump, which uses animate energy for its operation. It is a non-polluting, low cost foot operated two-cylinder pump, for which the ground water level must be less than six meters from the surface. It is recommended to lift water from 1.5" to 4" bore wells or from surface water, rivers, ponds, streams, canals, wells etc.



The Indo-Gangetic plain and the sedimentary plain running along India's east coast is best-suited area where KBP can be successfully put to use. This technology, developed by International Development Enterprises (IDE), is most suited for the plains and coastal region of South Asia with high water table.

The “Krishak Bandhu” pump (KBP) is one of the best examples of the efficient utilization of animate energy for low cost irrigation, available at present to the category of farmers which are referred as marginal and sub-marginal farmers (0.25 to 0.75 acre) at affordable cost.

Krishak Bandhu delivers on an average of 4,500 liters (KBP size-3.5" dia) and 7,200 liters (5" dia) per hour respectively. KBP is a device that assures this category of farmers a performance that will pay them a rate of return that fully matches with their efforts and investments.

The "Krishak Bandhu" Pump (KBP) relieves the individual poor farmers from the headaches of arranging pumping-sets operated on the diesel and electricity, as well as from the long wait for the hired diesel pump sets during the peak agricultural seasons, thus ensuring reliable irrigation, which is well within his own control.

The greatest advantage of KBP is that the entire technology is within the reach and control of the farmer. It is an example of an animate energy that has been demystified and the farmer can install the pump, repair, maintain and dismantle it. Farmers can increase their earnings up to 400% in two seasons ("Rabi" and "Kharif", refers to winter and rainy crop season, respectively in India) and recover their investment rapidly. The practical field experience of NGOs promoting KB pumps in India shows that many small, marginal and sub-marginal farmers are now free from earlier worries and financial burden and have become self-reliant.

The cost of "Krishak Bandhu" Pump (KBP) varies from Rs.3000 to Rs.4500 including the cost of pipes, basic accessories and installation, depending on a model that the farmer chooses.

3.2.6 Electricity/Energy Conservation

Commonly 50-90% electricity is wasted. Simple light bulb converts only less than 5% of electric energy into light; rest goes waste as heat. Many other applications are similarly wasteful. To avoid wasteful uses energy efficient equipments do exist in market. Its prices are minimal compared to the cost of electricity that is incurred. By employing the energy efficient equipment the power crisis in South Asia can be halved. For the society it is better and cheaper to switch over to energy efficient equipments than building



new power plants and power transmission lines. Use of other forms of energy is also wasteful, whether it is oil, gas, firewood, or others.

Light

Compared with traditional light bulbs, the compact fluorescent lights (CFLs) and light tubes are 4 times as efficient and new light emitting diodes (LEDs) are twice as efficient. Please refer Table.3.3 for examples of traditional and efficient light sources.

Poor qualities of fluorescent lights have short life while poor quality LEDs get weaker after some years. LEDs are fast improving, and LEDs of old design are not as efficient as the latest types.

Fluctuation in voltage can harm all types of lighting. It reduces life of devices. LEDs also damage when used in high temperatures without cooling. In the following are energy conservation proposals for households, business, and agriculture.

3.2.6.1 Electricity/Energy Conservation Tips

Tips for electricity conservation at home

1. Use efficient light and equipments.
2. Use appropriate lighting according to requirement. A so-called zero bulb, uses 12-15 Watt per hour. Compact fluorescent lamps (CFLs) are available in 5, 7, 9, and 11 Watt capacities and they give more light output.
3. A tube light (36/40 Watt) gives more light than 60-100 Watt bulb and will consume 40-60% less power. Tube light with electronic choke is more energy efficient.
4. For electric water heating instant geysers are considered to be more efficient than storage type geysers; but solar water heating use almost no electricity.
5. Efficient refrigerators use only 25% of the electricity that wasteful types use, for the same size.
6. Allow heated foodstuff to cool down before placing it in the refrigerator.
7. Electronics consume lot of electricity. Equipment with flat LCD screens use less energy than old screens, while the flat Plasma screens use more than most of the older screens. Large screens use more energy than small screens. The most efficient computer screens use 20 Watt, while rest of the computers use 50 Watt and a television (17" screen) 60 Watt. Much of the equipments use large part of the power when it is turned standby. This is also true for small devices such as mobile phone chargers, some telephones, etc.
8. Design houses to cool naturally to avoid or reduce use of air-conditioning.

Tips for electricity conservation at shops and business establishments

1. Use efficient equipment for light, cooling, cooking, etc.
2. Do not use electricity when less polluting/cheaper alternatives exist such as efficient use of biomass and solar heating for all heating / cooking purposes.
3. Design houses for natural cooling and use only the most efficient air-conditioners.
4. Avoid excessive illumination. Keep only as many fans and lights on as you need.
5. Do not use neon signboards. Use painted signboards.
6. Use energy saving compact fluorescent lamps for the illumination of your shops, showrooms, or hotels.
7. Use solar water heaters for hot water requirements of your hotels and lodges.

Tips for energy conservation in industrial establishments

1. Undertake regular Energy Audits and monitor energy consumption closely.
2. Use efficient equipment for cooling, motors, ventilation, etc.
3. Use variable speed drives to run pumps, machines etc. with only the necessary speed.
4. Plug all oil leakages. Leakage of one drop of oil per second amounts to loss of >2000 litres/year.
5. Incomplete combustion leads to wastage of fuel. Observe the colour of smoke emitted from chimney. Black smoke indicates improper combustion and fuel wastage. White smoke indicates excess air and hence loss of heat. Hazy brown smoke can indicate too many particles in combustion.

Tips for electricity conservation in agriculture

1. Use efficient equipment and keep equipment maintained.
2. Selection of right capacity of pumps according to the irrigation requirement.



3. Matching of pump set with source of water — canal or well.
4. Matching of motor with appropriate size pump.
5. Proper installation of the pump system — shaft alignment, coupling of motor and pump.
6. Use of low friction rigid pipes and foot valves.
7. Avoid using unnecessary bends and throttle valves.
8. Use bends in place of elbows.
9. The suction depth of 6 meters is recommended for centrifugal pumps. The delivery line should be kept at minimum.
10. Check pump system periodically and carry out corrective measures like lubrication, alignment, tuning of engines and replacement of worn-out parts
11. Over watering can harm the crops and allows wastage of vital water resource. Irrigate according to established norms for different crop.
12. Use drip irrigation for specific crops like vegetable, fruits, tobacco, etc. Drip systems can conserve up to 80% water and reduce pumping energy requirement.

3.3 OTHER DEVICES

In addition to the cooking, mechanical and electrical devices there are other mixed type of devices that tap the renewable energy and serve different purposes of the farmers and rural populations.

3.3.1 Drying

Open sun drying of various agricultural produce is the most common application of solar energy. With the objective of increasing drying rate and improving quality of the produce natural convection and forced convection type solar dryers have been developed for various commodities. The movement of air in the forced convection solar dryer is through a power blower, whereas in natural convection solar dryer air moves through the produce due to natural thermal gradient.

3.3.1.1 Domestic Solar Dryer

This is a small dryer meant for domestic uses of drying small quantities of products such as vegetables, fruits, condiments and spices. In this dryer, the convection of heated air is natural due to difference in temperatures. Solar energy is intercepted on the inclined aperture, which is glazed for trapping infrared radiation, and prevents unnecessary circulation of ambient air thereby maintaining the requisite temperature inside. The drying trays have been arranged one over the other on an inclined plane so that there is free circulation of heated air through the mass kept for drying. The products can be dried under shade or exposed to sunrays as desired. The dryer has provision for changing inclination of the aperture by 15° to capture more solar energy depending upon the season. Castor wheels make orientation easy in order to capture maximum solar radiation.

The drier may be left unattended even during rains, as the products kept inside are not affected.





3.3.1.2 Step Type Solar Cocoon Stifler

Silk cocoon stifling is generally carried out using an electric oven or by using firewood and boiling water. The heat needed to kill the pupa is obtained from solar radiation in a solar cocoon stifler. If the pupas are not killed at the right time they grow out of the cocoon, damaging the silk fibres. Hence stifling kills the pupa and 12-15 days time is available for reeling the silk fibres. The solar cocoon stifler is a box type unit that is provided with insulation and double glazed cover for trapping solar heat. Wire mesh trays are arranged horizontally inside the stifler and can be loaded easily by opening the side panels. It has a small fan for recirculating air for uniform heat distribution. An electric heater of 2 KW and thermostatic control is also provided to supply adequate heat during adverse weather. The quality of cocoon stifled in the solar stifler is similar to the cocoon stifled in the conventional process using the electric oven.

3.3.1.3 Simple Pyramid Shaped Solar Dryer

This dryer is conduction-convection type, pyramid shaped solar dryer with a base to height ratio of 1:1.5. The frame of the dryer is fabricated from wood and the trays (which also act like racks) are also of wooden frame and wire mesh. UV stabilized black polythene sheets cover the dryer. Since the wooden-wire-mesh trays are stored vertically, one over the other, the dryer allows an effective drying area equal to twice the size of the base area.

In summers the dryer attains temperatures of up to 15° to 20°C more than ambient and in winters about 5° to 10°C more than the ambient. Sunlight falling on the black UV stabilized polythene sheet heats up the sheet.

The heat absorbed by the sheet heats the air inside the pyramid shaped dryer. As the air gets heated inside, the convectional currents are initiated due to variations in the air densities.

Hot air moving up to the top of the dryer carries moisture as vapour from vegetables or fruits kept inside for drying in the wooden-wire-mesh trays/ racks. The holes provided at the top of the dryer allow the hot vapour to escape. Comparative colder air is drawn from outside through holes provided at the base of the dryer.

This Cycle of hot air escaping from the top and colder air being drawn from the base of the dryer removes the moisture and dehydrating the materials, facilitating faster drying of the vegetables, fruits or herbs in this solar dryer. Fruits like Apple, Banana and vegetables like Ladies finger, Bitter gourd, Cauliflower, Onions etc. can be dried in this dryer. Since the materials do not directly come in contact with Sunlight in this dryer, the materials retain their Colour on drying. The green leafy materials, like spinach, Mehandi (Henna), Tulsi (Basil leaves) and Neem (Margosa) leaves dried in this solar dryer retain almost its natural green colour even when dried. Standard model solar dryer (shown in the photo) can dry about 20-kg of fresh vegetables, reducing weight to 2 to 3-Kg in two Sunny days.



At the present Cost of materials are incorporated in making this dryer, the standard model is prized at Rs. 2500. This dryer is being sold in North India around Delhi. Life of this solar drier is 5 years.

3.3.1.4 Data on Solar Dehydration of Selected Foods

Process data for fruits, vegetables, green leafy vegetables, spices, food items is given in Table.3.4.

Table.3.4

Sl. No	Product	Drying Time (hrs)	Yield (%)	Ambient Temp. (°C)	Cabinet Temp. (°C)
F R U I T S					
1.	Mango Bar (10mm Thick)	20	45	40	65
2.	Pineapple Bar (10mm Thick)	20	45	30	51
3.	Papaya Bar(10mm Thick)	20	45	30	51
4.	Guava Bar (10mm Thick)	35	45	31	48
5.	Grapes	25	20	31	53
6.	Sapota Slices	8	27	34	49
7.	Sapota Bar (10mm Thick)	20	36	34	42
V E G E T A B L E S					
8.	Potatoes	4	30	31	50
9.	Donda	19	30	31	51
10.	Carrot	10	15	31	51
11.	Tomato	10	10	33	60
12.	Mushrooms	12	15	33	50
13.	Bitter gourd	6	11	26	42
14.	Onion	18	17	31	51
15.	Amchur powder	7	10	31	60
16.	Coconut	5	5	31	50
G R E E N L E A F Y V E G E T A B L E S					
17.	Curry leaves	8	35	29	55
18.	Spinach leaves	15	8	29	55
19.	Fenugreek leaves	6	13	27	40
20.	Tamarind leaves	12	11	29	55
21.	Gogu leaves	15	16	30	55
22.	Mint leaves	5	17	29	55
23.	Drumstick leaves	5.5	15	29	55
24.	Coriander leaves	6	12	30	51
S P I C E S					
25.	Ginger powder	20	15	31	50
26.	Mango Ginger	10	16	26	40
27.	Garlic Powder	4	33	26	45
28.	Red Chillies	15	34	32	56
29.	Green chillies	6	12	40	25
30.	Pepper	8	34	30	55
F O R E S T P R O D U C E					
31.	Karaya Gum	19	30	35	58
32.	Karakkaya	44.5	47	29	44
33.	Sugandapala (Budipalagadda)	26	26.5	29	62
34.	Aloevera	9	2.8	33	49
35.	Amla	6.5	32	31	50
36.	Honey	5.5	91.5	39	65
M E D I C I N A L & H E R B A L P R O D U C T S					
37.	Rosemary	15	30	32	58
38.	Spirulina Powder	6	18	25	60
39.	Tulasi leaves	6	12	31	50
F O O D I T E M S					
40.	Maida	4	96	32	56
41.	Vermicelli	4	35	31	49
42.	Noodles	4	77	28	44
43.	Pickled Chillies	24	25	31	49
44.	Fish	8	40	28	52
C H E M I C A L P O W D E R					
45.	Silicon Carbide	3	80	31	60
46.	Cellulose	7	50	32	60

3.3.2 Solar Water Heater

Water heating is one of the most common applications of solar energy for domestic and industrial applications. Like solar dryers the water-heating systems are also available in natural convection and forced convection designs. Natural convection water heating system is also known as thermo-siphon water heating system that consists of a flat plate solar collector, insulated water storage tank and necessary insulated pipe fittings. Solar water heaters collect sun energy. They usually have rooftop solar collectors with arrays of piping and net of metal sheets.



Solar water heaters collect the sun's energy usually with rooftop solar collectors with arrays of piping and net of metal sheets, painted black to absorb as much radiation as possible, and a hot water storage tank to enable hot water use at night. Usually the collectors are encased in glass or plastic and angled towards south to catch and absorb maximum sunshine. They are painted black to absorb and retain as much radiation as possible. The collectors act as miniature greenhouses trapping heat under their glass plates. In areas where air freezes the solar collectors must be filled with anti-freeze or emptied when frost risk occurs. In warmer areas, the water for use can be circulated directly through the collector. If the storage tank is above the collector, the hot water can circulate from the collector to the storage having natural convection' no pump is required.

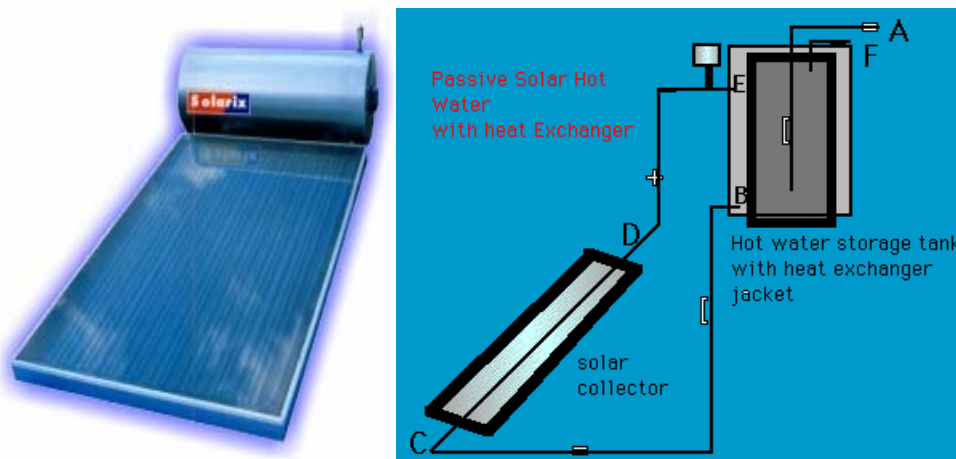

The size of solar collectors needed vary greatly with location and the acceptance of less hot water some days. In a location with a minimum insolation of 4 kWh/day in monthly average, such as most of South Asia, choose 3 M² per 100 ltr of daily hot water use (tjek). That will give sufficient hot water except for a few days a year. The hot water tank should be large enough to store hot water from day till night, often is used the same size as the daily hot water use; but if most hot water is used during the day, it can be smaller. The tank must be insulated well enough to keep the temperature during the night, with for instance maximal 5°C temperature loss.

Efficiency of solar water heaters to convert sun energy into heat energy is 25-50%. The efficiency actually depends on the system and how much the water temperature is higher than the surrounding temperature. Daily solar energy inflow varies between 4 and 8 kWh/m² as monthly average in typical South Asian locations. It gives heat production of 1-4 kWh/m² per day depending on type, usage, etc.

The system need to be installed by people with plumbing skills. A short training (a few days) on special requirements for solar water heaters is an advantage, in particular to avoid design flaws where the hot water is cooled by unwanted circulation or un-insulated pipes or tank. The pipes and system must be good enough to withstand corrosion of the water used, and the pipe-combination that can cause corrosion must be avoided (such as iron and copper in the self-circulating system). The collectors must be placed in free sunshine, faced south or horizontally. The inlets and outlets of the tank should be placed so cold water is not mixed with hot water outlet. Cold water should be let into the tank in the bottom, preferably in a horizontal inlet.

A regular inspection by skilled people is recommended, for instance every 2 years. In systems with back-up heating, such as electric water heating, it is recommended to turn off the back-up heating from time to time to test the output of the solar heating. Lifetime solar hot waters are often 15-20 years if well maintained and if corrosion problems are avoided.

Solar hot water is used for washing, showers and cleaning, as well as for industrial appliances. An important application is in health facilities. In off-grid installations a 'high hot water tank' can be used as storage tank, filled with hot water once a day in the morning. High-temperature collectors with mirrors to concentrate the sunlight (parabolic dish or trough shaped) can produce steam that can be used in industries or in special solar power plants.

Estimated cost is approximately Indian Rupees. 18000 (IRP) for a 100 litres capacity SWH. For higher capacity it ranges from Indian Rs. 110 to Indian Rs. 150 per installed litre.



Applications:

Residential Buildings – Domestic Systems: The domestic solar hot water systems substitute or supplement electrical geysers in bathrooms and kitchens used for bathing and washing purposes.

Institutional/Commercial SHW Systems: Commercial uses of solar hot water systems are in hotels, hostels, hospitals, holiday resorts and pilgrim centers. Most of the institutional systems are large-scale hot water plants ranging from 1,000 to 10,000 liters storage capacity. The systems are 'forced circulation' ones fitted with electrical pumps to aid the circulation.

Industrial Systems: Boilers supply low-pressure steam ranging from 110 °C to 150 °C. Source of energy in the conventional boilers is furnace oil or coal. As energy conservation measure, solar hot water systems can be used for pre-heating of boiler feed water to meet the energy requirement partly. Flat plate collectors can provide hot water at about 80 °C on sunny days at locations having favorable climatic conditions.

3.3.3 Solar Distillation

Solar basin still consists of a simple blackened box for storing and heating water. This box is provided with a glazed top, which serves the purposes of both insulator and condensing surface. The glazed top is kept at an angle to allow the condensed water to flow to one side and into a small gutter. Bottom of the unit is insulated with glass wool to improve the efficiency. Solar energy is allowed into the collector to heat the water. When water gets heated to a certain temperature it evaporates and condenses on the underside of the glass. Rising of only the water vapor leaves contaminants behind, thus purifying the water.

The gentle slope of the glass directs the condensate to a collection trough, which in turn delivers the water to the collection bottle. The still is filled each day with twice the quantity of water than distilled water produced by it. The still is also fitted with overflow outlets, which allow the excess water to flush the still every day. A major advantage of the basin still is that it does not require a pressurized water supply.

Solar still is a useful device to get fresh/distilled water that is required in industries, hospitals and dispensaries, garages and automobile workshops, telephone exchanges, laboratories and marshy and coastal area.

3.3.4 Solar Disinfection and Purification of Water

There are a few methods commonly advocated for the disinfection of drinking water at the household level. These include boiling of water for about 10 minutes or the use of certain chlorine compounds available in the form of tablets. As each of these procedures has its own drawbacks, their application is extremely limited in the developing countries, where water-borne diseases are most common, and the purity of drinking water supplies from external sources cannot be assured.

Boiling of water and condensation using fuel and use of tablets or proper solution is neither cost effective nor convenient. The experiments conducted on solar disinfection of drinking water at the American University of Beirut for two years concluded that the rate of destruction of bacteria actually depends upon a number of influencing factors such as:

- intensity of sunlight at the time of exposure, which in turn depends upon the geographic location (i.e. latitude), seasonal variations and cloud cover, the effective range of wavelengths of light, and the time of day;
- kind of bacteria, the nature and composition of the medium, and the presence of nutritive elements capable of supporting the growth and multiplication of various microorganisms;
- characteristics of the containers/bottles in which the contaminated water is kept during exposure (e.g. colour, shape, transparency to sunlight, size, and wall thickness);
- clarity of water (i.e. degree of turbidity) and its depth are important factors that determine the extent of penetration of sunlight, and to what extent they have the possibility of shielding the microorganisms from its lethal effects.



Based on the above finding and analysis, it became clear that sunlight with wavelengths ranging from 315 nm to 400 nm is the most lethal region, as it accounts for about 70% of the bacterial destruction potential. The wavelength of this band is known as the near-ultraviolet region of the light spectrum.

Visible light is characterized by having wavelengths ranging from 400 nm to about 750 nm, and accounts for about 30% of the bacterial destruction capacity. Accordingly, the most appropriate colours of the containers/bottles have to be selected that would yield optimum results in terms of microbial destruction. While violet /blue have better effect as compared to green/ yellow/ orange/ red tinted bottles, the colourless plastic bottles are the best for the purpose. Very light green containers may also be used provided the period of exposure to sunlight is somewhat extended.

Thus, preference should be given to containers that are either colourless or blue in colour. The brown colour bottles and to a lesser extent red ones, are recommended for the storage of water. Therefore, storing the of water by exposing it to the solar rays using appropriate colour containers/bottles could be one of the most economical way for the disinfection and purification of water for drinking purpose by the rural households, especially the poor peasants living in the remote and far-flung areas/regions of the developing countries.

- Container needs to be exposed to sun for 6 hours if the sky is bright or up to 50% cloudy,
- Container needs to be exposed to the sun for 2 consecutive days if the sky is 100% cloudy,
- During days of continuous rainfall, SODIS does not work, and
- If a water temperature of at least 50 °C is reached, an exposure time of 1 hour is sufficient.

3.3.5 Solar powered drinking water UV disinfection unit

This solar powered drinking water UV disinfection unit, named as “Nedap,” is developed by ‘NAIADE’, The Netherlands. The Nedap is capable of producing 2,500 liters/day of bacteria and virus free water, which can cater to the drinking water needs of about 800-1,000 people per day. The unit is stand-alone, requires no maintenance other than cleaning the PV panel.

Spare parts like the UV lamp needs replacement only after 10,000 hrs of operation. It is reported to be providing water as per the WHO standards. It can be installed within 30 minutes and can be used at all places since it needs no fossil fuel or electricity.

Filtration of unsafe water is done by washable bag filters and disinfection by UV. The unit weighs less than 75 kg and is shipped in ready-to-use packed palletized box.

Technical Data	
Energy Source	Sunlight
Solar Panel	75 watt
Energy Storage	Battery
Daily Av Capacity to Purify	2,500 ltrs / 8 hrs of sunlight
Water Pre-filters	Included
UV Disinfection Lamp	20 watt
Water Tank storage Cap	100 litres
Weight	44 kg
Dimensions	54 x 75 x 140 cm (excluding solar panel)
Effective Against	viruses, bacteria, protozoa & worm eggs



The unit has been tested and approved by various leading water research labs worldwide, such as UNESCO-IHE, Ghanaian Water Research Institute, Atitra India, KIWA, and many more.

3.3.6 Passive Cooling and Heating of Rooms

‘Passive design’ is the design that does not require mechanical heating or cooling. Homes that are passively designed take advantage of natural energy flows to maintain thermal comfort. Passive design in your home:

- Significantly improves comfort.
- Reduces or eliminates heating and cooling bills.
- Reduces greenhouse gas emissions from heating, cooling, mechanical ventilation and lighting.

Building envelope’ is a term used to describe the roof, walls, windows, floors and internal walls of a home. The envelope controls heat gain in summer and heat loss in winter. Its performance in modifying or altering climatic extremes is greatly improved by passive design.



Well-designed envelopes maximize cooling air movement and exclude sun in summer. In winter, they trap and store heat from the sun and minimize heat loss to the external environment. Buildings, as they are designed and used today, contribute to serious environmental problems because of excessive consumption of energy and other natural resources. Demands of energy use in buildings and environmental damage arise because of energy-intensive solutions sought to meet the requirements of heating, cooling, ventilation and lighting.

However, buildings can be designed to meet the occupant's need for thermal and visual comfort at reduced levels of energy and resources consumption. Energy consumption in new constructions can be controlled by way of adopting an integrated approach to building design. Primary steps in this approach are as below:

- Incorporate solar passive techniques in a building design to minimize load on conventional systems (heating, cooling, ventilation, and lighting)
- Design energy-efficient lighting and HVAC (heating, ventilation, and air-conditioning) systems.
- Use renewable energy systems (solar photovoltaic systems/solar water heating systems) to meet a part of building load.
- Use low energy materials and methods of construction and reduce transportation energy.

Climate and Architecture

India is divided into six climatic zones based on different climatic conditions. Knowledge of climate at a given location can help in the design of solar passive buildings that eliminate the adverse effects of climate, yet simultaneously take advantage of effects that are beneficial. For instance, in a place like Mumbai (Indian coastal mega city), a building can be designed in such a way that appropriate shading prevents solar radiation and adequate ventilation reduces humidity. In a place like Shimla (Indian hill station), where the climate is cold and cloudy, a building can be designed to make maximum use of sunlight, and thereby keep its interiors as warm as possible. The various climatic factors that affect the solar passive design are listed below:

- Wind velocity
- Ambient temperature
- Relative humidity
- Solar radiation

3.3.6.1 Solar Passive Techniques

Various concepts and techniques are used to design energy-efficient buildings. Some of these are as described below:

Direct heat gain

The direct heat gain technique is generally used in cold climates. The basic principle is that sunlight is admitted into the living spaces directly through openings or glazed windows to heat walls, floors, and inside air. The glazed windows are generally located facing south to receive maximum sunlight during winter. They are usually double-glazed with insulated curtains to reduce heat loss during the night. During the day the heat is stored in walls and floors.

Thermal storage walls

In this approach, a thermal storage wall is placed between the living space and the glazing. It prevents solar radiation to enter the living space. Radiation is absorbed by the storage wall, and then transferred into the living space. Thermal storage walls include brick, cement and clay walls, water walls, transwalls.

Evaporative cooling

Evaporative cooling is a passive cooling technique generally employed in hot and dry climates. It works on the principle that when warm air is used to evaporate water the air itself becomes cool.

Passive desiccant cooling

Passive desiccant cooling method is effective in a warm and humid climate. Natural cooling of the human body through sweating does not occur in highly humid conditions. To decrease the humidity level of the surroundings, desiccant salts or mechanical de-humidifiers are used.

Induced ventilation

Passive cooling by induced ventilation can be most effective in hot and humid climates as well as in hot and dry climates. This method involves the heating of air in a restricted area through solar radiation; thus, creating a temperature difference and causing air movements or drafts. The drafts cause hot air to rise and escape from the interior causing effecting cooling.

Earth berming

Earth-berming technique is used for both passive cooling and heating of buildings. It is based on the fact that the earth acts like a massive heat sink. Thus, underground or partially sunk buildings remain cool in summer and warm in winter.

In addition to above concepts, there are many other solar passive techniques such as wind towers, earth air tunnels, curved roofs and air vents, which can be incorporated according to the requirements of the buildings.

Advantages of solar passive buildings

With the incorporation of solar passive concepts into a building a large quantity of energy can be saved. Furthermore, these concepts help provide comfortable living conditions to the inhabitants in an eco-friendly manner. However, they cannot totally eliminate the use of conventional energy for modern facilities such as air-conditioning.

Cost and payback period

The cost of a building may increase by about 5-15% because of incorporation of solar passive concepts. However, the investment may be recovered within a period of 1-7 years due to energy savings.

3.3.6.2 Passive Solar Heating

Passive solar heating is one strategy of 'solar design'. When combined properly, this strategy can contribute to heating, cooling, and day lighting of any building. Passive solar heating in particular uses building components to collect, store and distribute solar heat gains to reduce the demand for space heating. It does not use mechanical equipments because the heat flow is by natural means (radiation, convection & conductance) and thermal storage is in the structure itself.

It is best to incorporate passive solar heating into a building during the initial design. Window design, especially glazing choices, is a critical factor for determining the effectiveness of passive solar heating. Passive solar systems do not have a high initial cost or long-term payback period, both of which are common with many active solar heating systems. In hot climates, large south-facing windows are used, as these have the most exposure to the sun in all seasons. Although passive solar heating systems do not require mechanical equipments for operation, yet fans or blowers should be used to assist the natural flow of thermal energy. Thus, the passive systems assisted by mechanical devices are referred to as 'hybrid' heating systems.

Architectural design of the building usually consists of: buildings with rectangular floor plans, elongated on an east-west axis; a glazed south-facing wall; a thermal storage media exposed to the solar radiation which penetrates the south-facing glazing; overhangs or other shading devices which sufficiently shade the south-facing glazing from the summer sun; and windows on the east and west walls, and preferably none on the north walls.

The following are general recommendations that should be followed in the design of passive solar heated buildings:

- » Passive solar heating will tend to work best, and be most economical, in climates with clear skies during the winter and where alternative heating sources are relatively expensive.
- » Use passive solar heating strategies only when they are appropriate. Passive solar heating works better in smaller buildings where the envelope design controls the energy demand.
- » Careful attention should be paid to constructing a durable, energy-conserving envelope of building.
- » Address the orientation issues during site planning. To the maximum extent possible, reduce east and west glass and protect openings from prevailing winter winds.

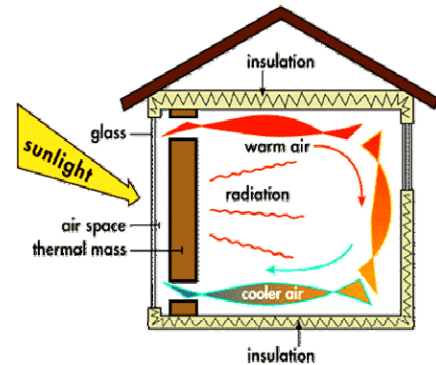

Design of Passive Solar Heated

- » Specify an airtight seal around windows, doors and electrical outlets on exterior walls. Employ entry vestibules; and keep any ductwork within the insulated envelope of the house to ensure thermal integrity. Consider requiring blower-door tests of model homes to demonstrate air-tightness and minimal duct losses.
- » Specify windows and glazing that have low thermal transmittance values (U values) while admitting adequate levels of incoming solar radiation (higher Solar Heat Gain Coefficient). Data sources, such as the National Fenestration Rating Council "Certified Products Directory", should be consulted for tested performance values. The amount of glazing will depend on building type and the climate.
- » Ensure that the south glass in a passive solar building does not contribute to increased summer cooling. In many areas, shading in summer is just as critical as admitting solar gain in winter. Use your summer (B) and winter (A) sun angles to calculate optimum overhang design.
- » Avoid overheating. In hot climates, buildings with large glass areas can overheat. Be sure to minimize east- and west-facing windows. For large buildings with high internal heat gains, passive solar heat gain is a liability because it increases cooling costs rather than saving costs of space heating.
- » Design for natural ventilation in summer with operable windows designed for cross ventilation. Ceiling fans or heat recovery ventilators offer additional air movement. In climates with large diurnal temperature swings, opening windows at night will release heat to cool night air. Closing the windows on hot days will keep the building cool naturally.
- » Provide natural light to every room. Some of the most attractive passive solar heated buildings incorporate elements of both direct and indirect gain.
- » If possible, elongate the building along the east-west axis to maximize the south-facing elevation and the number of south-facing windows that can be incorporated.
- » Plan active living or working areas on the south and less frequently used spaces, such as storage and bathrooms, on the north. Keep south-facing windows to within 20° of either side of the south.
- » Improve building performance by employing high-performance, low-glazing or nighttime, moveable insulation to reduce heat loss from glass at night.
- » Locate obstructions, such as landscaping or fences, in a way that full exposure to the sun.
- » Include overhangs or other devices, such as trellises or deciduous trees, for shading in summer.
- » Reduce air infiltration and provide adequate insulation levels in walls, roofs and floors.
- » Select an auxiliary HVAC system that complements the passive solar heating effect. Resist the urge to oversize the system by applying "rules of thumb."
- » Make sure there is adequate quantity of thermal mass. In passive solar heated buildings with high solar contributions, it can be difficult to provide adequate quantities of effective thermal mass.
- » Design to avoid sun glare. Room and furniture layouts need to be planned to avoid glare from the sun on equipment such as computers and televisions.

Five Elements of Passive Solar Home Design

Following five elements constitute a complete passive solar home design. Each performs a separate function, but all five must work together for the design to be successful.

Aperture (Collector): It is the large glass (window) area through which sunlight enters the building. Typically, the aperture(s) should face within 30° of true south and should not be shaded by other buildings or trees from 9 a.m. to 3 p.m. each day during the winter season.

Absorber: It is the hard, dark surface of the storage element. This surface, which could be that of a masonry wall, floor, partition (phase change material), or water container, sits in the direct path of sunlight. Sunlight hits the surface that is absorbed as heat.

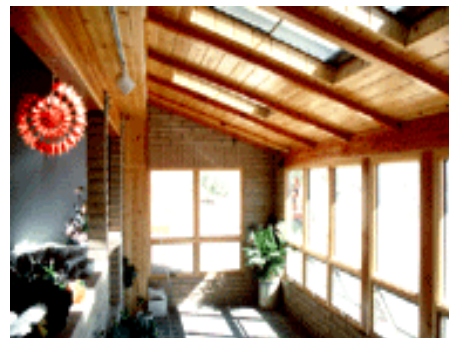

A sunspace or attached greenhouse relies primarily on convection to move heat from the sunny space to other adjacent rooms.

Thermal Mass: The materials that retain or store the heat produced by sunlight are 'thermal mass'. Difference between the absorber and thermal mass, although they often form the same wall or floor, is that the absorber is an exposed surface whereas thermal mass is the material below or behind that surface.

Distribution: Distribution is the method by which solar heat circulates from the collection and storage points to different areas of the house. A strictly passive design will use three natural heat transfer modes— conduction, convection, and radiation— exclusively. In some applications, however, fans, ducts and blowers may help with the distribution of heat through the house.

Control Roof: Overhangs can be used to shade the aperture area during summer months. Other elements that control under- and/or overheating include electron sensing devices e.g. differential thermostat that signals a fan to turn on, operable vents and dampers that allow or restrict heat flow, low-emissive blinds, and awnings.

Advantages

- Passive solar design is highly energy efficient that reduces building's energy demands for lighting, winter heating and summer cooling. Energy from the sun is free. Strictly passive designs capture it without additional investments in mechanical and electrical "active solar" devices such as pumps, fans and electrical controls.
- Passive solar design also helps conserve valuable fossil fuel resources so that they can be directed toward other uses. Incorporating passive solar design elements into buildings and homes can reduce heating bills by 50%. Day lighting, a component of many passive solar designs, is one of the most cost-effective means of reducing energy usage in buildings.
- A well-designed and built passive solar building does not have to sacrifice aesthetics either. It can be as attractive as conventionally designed buildings and still save energy and money.
- Passive solar design also reduces greenhouse gases that contribute to global warming.

Disadvantages

- In areas where experienced solar architects and builders are not available, construction costs can run higher than for conventional homes, and mistakes can be made in the choice of building materials especially window glass. Passive solar homes are often built using glass that, unfortunately, rejects solar energy. Such a mistake can be costly. Choosing glass for passive solar designs isn't easy. The right glass choice depends on which side of the building (east, west, north or south) the glass is installed and the climate.
- In addition, room and furniture layouts need to be planned carefully to avoid glare on equipment such as computers and televisions.
- During the summer or in consistently warm climates, day lighting could actually increase energy use in a building by adding to its air-conditioning load.

3.3.6.3 Tromb  Wall

Tromb  Wall is a passive solar heating system. Tromb  wall is a sun-facing wall built from material that can act as a thermal mass (such as adobe, stone, concrete or water tank), combined with an air space, insulated glazing and vents to form a large solar thermal collector. By attaching a translucent cover (fibre-glass board or glass) on the vault, the sun heating effect is created. The absorbing vault face should be painted black in order to absorb as much heat as possible.

During the day, sunlight shines through the glazing and heats the surface of the thermal mass. At night, heat escapes from the thermal mass, primarily to the outside. Because of the insulating glazing the average temperature of thermal mass can significantly be higher than average outdoor temperature. If the glazing insulates well enough and outdoor temperatures are not too low, the average temperature of thermal mass will be significantly higher than room temperature, and heat will flow into the house interior. Indirect gain is that the Tromb  wall stores heat during the day. Excess heat is vented to the interior space. At night, Tromb  wall vents are closed and the storage wall radiates heat into the interior space.

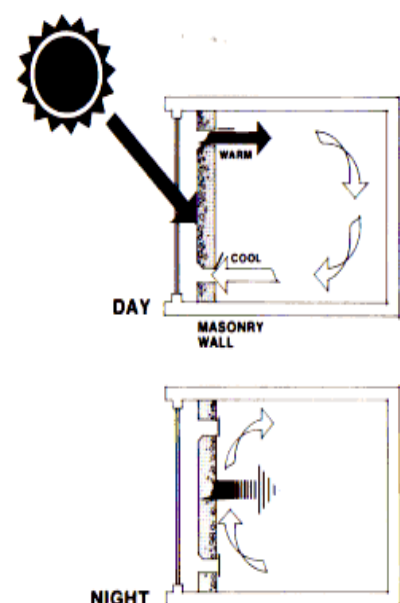

Common Modifications to the Tromb  wall:

- Exhaust vent near the top is opened to vent during the summer. Such venting makes the Tromb  wall pump in the fresh air during the day even if there is no breeze.
- Windows in the Tromb  wall though lower the efficiency, but they may be fitted for natural lighting or aesthetic reasons. If the outer glazing has high ultraviolet transmittance and the window in Tromb  wall is of normal glass, this uses ultraviolet light efficiently for heating purpose while protecting people from its harmful effects.
- Electric blowers controlled by thermostats are used to improve air and heat flow.
- Fixed or movable shades, which can reduce nighttime heat losses, might be fitted in the wall.
- It may be trellises to shade the solar collector during summer months.
- Insulating cover can be used at night on the glazing surface.
- Tubes, pipes or water tanks make part of a solar hot water system, and fish tanks as thermal mass.
- Selective surface can be increased for more absorption of solar radiation by the thermal mass.

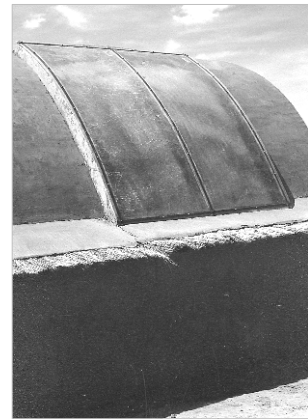

The specific Lak'a Uta Tromb  wall, built in Bolivia, is mounted to the roof after plastering. It is simple frame of prefabricated concrete elements (or small adobes). For glazing (translucent cover) flat fiber plastic boards (calamina pl stica) are used. Black paint or black colored earth-mud-plaster is used to make absorbing vault face.

Benefits of Tromb  Wall

- Low or zero energy consumption for heating
- Non-toxic; and low cost

Limitations of Tromb  Wall

While, the Tromb  walls are an effective alternative to heating from stoves or heaters; however the design is neither simple nor easily comprehensible. A number of pre-conditions must be considered, especially, the design application, thermal conditions (well insulated, accumulation of heat, etc.) and maintenance. Before opting Tromb  as low cost housing in cold climate, it is recommended to do a thorough preliminary study and appropriate detailed design. A number of web pages can help the specific design process. See the Laka Uta Tromb  manual.

3.3.6.4 Passive Solar Cooling

Reducing Internal Heat Gain

- Turn lights off when not in use, and remove light bulbs in areas where they are not required;
- Turn water heater temperature down to 120   F;
- Take shorter showers, open the window and run the exhaust fan when showering;
- Install water heater insulation blanket, and insulate hot water pipes;
- Open window to utility room when the clothes dryer is in use during summer;
- Eat cold meals in the summer, and cook outside;
- Use microwave in the summer, and bake at night;
- Run exhaust fan when cooking;
- Use cold or warm water settings on washing machine;
- Wash clothes at night, and hang clothes outside;
- Dry larger loads; close off utility room;
- Turn computers and other electronic devices off when not in use;
- Unplug TV and stereo when not in use;
- Turn off furnace pilot light during the cooling season;
- Spend more time outdoor on porches and patios; and
- Switch off drying option on dishwasher.



Reducing External Heat Gain

- Plant shade trees, and build artificial shade structures such as arbors and trellises;
- Install awnings, and install and use window shades;
- Seal cracks in building envelope;
- Replace energy-inefficient windows;
- Repaint with a lighter color;
- Replace roof shingles with lighter ones or metal roofing or Spanish tiles; and
- Install radiant barriers.

Purge Heat

- Use natural ventilation early and late in cooling season;
- Purge out heat at night in dry climates;
- Install and use window fans, install attic fan, and install whole house fan;
- Improve efficiency of air conditioning system (seal ducts, replace dirty filters, shade air conditioner, etc.);
- Replace inefficient air conditioners with more efficient models;
- Install an air-source heat pump.

Insulation

Insulation is an essential component of passive design. It improves building envelope performance by minimizing heat loss and heat gain through walls, roof and floors.

Thermal mass

Externally insulated, dense materials like concrete, bricks and other masonry are used in passive design to absorb, store and re-release thermal energy. This moderates internal temperatures by averaging day/night (diurnal) extremes, therefore, increasing comfort and reducing energy costs.

Glazing

Windows and glazing are a very important component of passive design because heat loss and gain in a well insulated home occurs mostly through the windows.

Shading

Shading of glass is a critical consideration in passive design. Unprotected glass is the single greatest source of heat gain in a well insulated home. Shading requirements vary according to climate and house orientation. In climates where winter heating is required, shading devices should be installed so that it prevents the sun from coming inside during summer but allows full winter sun to penetrate. This is most simply achieved on north facing walls. East and west facing windows require different shading solutions to north facing windows. In climates where no heating is required, shading of the whole home and outdoor spaces will improve comfort and save energy.

Skylights

Well-positioned and high quality skylights can improve the energy performance of home and bring welcome natural light to otherwise dark areas.

3.3.7 Bio Diesel

Bio-diesel is an eco-friendly, alternative diesel fuel prepared from domestic renewable resources i.e. vegetable oils (edible or non-edible oil) and animal fats. These natural oils and fats are made up mainly of triglycerides. These triglycerides show striking similarity to petroleum derived diesel and are called "bio-diesel". As India is deficient in edible oils, non-edible oil may be raw material of choice for producing bio diesel.

India's Initiative

Conscious of the advantages, Government of India is now working towards evolving a national policy on bio-fuels as environmentally friendly energy source to reduce dependence on import of diesel. Further, Government of India has already established the National Hydrogen Energy Board to push the development of alternative fuel.



The main objective of this Board is to coordinate and develop national hydrogen energy roadmap with focus on development of alternative fuel for transport.

3.3.7.1 Technical Feasibility

In India, only 57% arable land is used intensively. Most of the area is cultivated during the monsoon. During the fallow period the land may be utilized for the oilseed crop. Moreover, the farming provides partial employment to considerably large size of rural population. This population is equivalent to the population of USA. So, growing plantations meant for bio-diesel can reduce both the problem of fallow lands as well as unemployment.

3.3.7.2 Sources of Bio-diesel

All trees bearing oilseeds, both edible and non-edible have the potential to be a source of bio-diesel. Among edible oilseeds soybean, sunflower, mustard, etc. are sources of bio-diesel. But, the edible oilseeds can't be used for bio-diesel production in most developing countries, and more particular in the South Asian countries as indigenous production does not meet the current demand. Thus, the South Asian countries should focus on non-edible oils like *Jatropha curcas*, *Pongamia pinnata*, *Azadirachta indica* (neem), etc. Among non-edible oilseeds plants, *Jatropha curcas* has been identified as the most suitable seed for India.

Viewing non-edible oil available from *Jatropha curcas* and its presence throughout the country, its capacity to rehabilitate degraded or dry lands, and its capacity to improve land's water retention capacity, *Jatropha curcas* is considered additionally suitable for up-gradation of land resources. Presently, in some of the Indian villages, farmers are extracting oil from *Jatropha curcas*. After settling and decanting they are mixing the filtered oil with diesel fuel. So far the farmers have not observed any damage to their farm machineries running on fuel mixed with bio-diesel. Oil content in *Jatropha curcas* is 35-40%.

The oil needs to be converted to bio-diesel through a chemical reaction called as 'trans-esterification'. This reaction is relatively simple and does not require any exotic material. Indian Oil Corporation (R&D) has been using a laboratory scale plant of 100 kg/day capacity for trans-esterification; designing of larger capacity plants is in the offing. These large plants are useful for centralized production of bio-diesel. Production of bio-diesel in smaller plants (of capacity of 5-20 kg/day) may also be started in villages.

From the point of view of air emissions the bio-diesel is superior to petro-diesel. It can provide energy security to remote and rural areas. It has good potential for employment generation also.



Optional Electric Drive

Advantage of *Jatropha curcas* is that it is a widely occurring species.

It grows practically all over India in variety of agro-climatic conditions.

It can be grown in arid zones (20 cm rainfall) as well as in higher rainfall zones and even on the lands with thin soil cover. Its plantation can be taken up as quick yielding even in adverse land situations viz. degraded and barren lands under forest or non-forest use, dry and drought prone areas, marginal lands and alkaline soils. It grows as a tree up to the height of 3-5 m. It is a good plantation for eco-restoration of all types of wastelands.

Table.3.5

State-wise area planted under *Jatropha* by NOVOD

State	Area (ha)
Andhra Pradesh	44
Bihar	10
Chhatisgarh	190
Gujarat	240
Haryana	140
Karnataka	80
Madhya Pradesh	260
Maharashtra	150
Mizoram	20
Rajasthan	275
Tamil Nadu	60
Uttaranchal	50
Uttar Pradesh	200

Table.3.6

Economics based on Planning Commission Report on Bio-fuels, 2003

Activities	Rate (Rs./Kg)	Quantity (Kg)	Cost (Rs.)
Seed	5.00	3.28	16.40
Cost of collection & oil extraction	2.36	1.05	2.48
Less cake produced	1.00	2.23	(-) 2.23
Trans-esterification	6.67	1.00	6.67
Less cost of glycerin produced	40 to 60	0.095	(-) 3.8 to 5.7
Cost of Bio-diesel per kg			19.52 to 17.62
Cost of Bio-diesel per litre (Specific Gravity 0.85)			19.52 to 14.98



Realizing the urgency and sheer need of producing bio-diesel, the Govt. of India has constituted National Oil Seed & Vegetable Oil Development Board (NOVOD).

Potential demand of petro-diesel by 2006-07 is 52 MMT and by 2011-12 it will increase to 67 MMT. By 2011-12, for 20% blend with petro-diesel the likely demand will be 13.4 MMT. To meet the requirement of 2.6 MMT of bio-diesel, plantation of *Jatropha* should be done on 2.2-2.6 million ha area of land. 11.2 - 13.4 million ha of land should be covered by year 2011-12 for 20% bio-diesel blending.

National Oilseed and Vegetable Oil Development Board (NOVOD) is making the following efforts:

- State/region wise systematic survey for identification of superior trees and superior seeds.
- Maintenance of record on seeds/trees. Samples of high yielding seeds to be sent to National Bureau of Plant Genetic Resources (NBPGR) for accession and cryo-preservation.

Table.3.7

Employment potential based on Planning Commission Report on Bio-fuels, 2003

Year	Jobs in plantation	Jobs in maintenance	Jobs in Operation of units
2006-07	2.5 million	0.75 million	0.10 million
2011-12	13.0 million	3.9 million	0.30 million

- NOVOD has developed improved *Jatropha* seeds, which have oil contents up to 1.5 times of ordinary seeds. However, being in short supply, initially these improved *Jatropha* seeds would be supplied only to Agricultural Universities for multiplication and development. After multiplication these would be supplied to different states for further cultivation. This program is likely to take 3-4 years. NOVOD is also working for development of multi-purpose post-harvest technology tools like decorticator and de-huller, which would improve oil recovery.

3.3.7.3 Indian States that promoted Bio-diesel considerably

Uttaranchal: The Uttaranchal Bio-fuel Board (UBB) has been constituted as a nodal agency for bio-diesel promotion in the state. The board has undertaken *Jatropha* plantation in an area of 1 lakh hectare. UBB has established *Jatropha* Gene Bank to preserve high yielding seed varieties and plans to produce 100 million liters of bio-diesel.

Andhra Pradesh: Government of Andhra Pradesh (GoAP) has encouraged *Jatropha* plantation in 10 rain shadow districts of AP. Task force for it has been constituted at district and state level. GoAP proposed *Jatropha* cultivation in 15 lakh acres in next 4 years.

Chhattisgarh: 6 lakh saplings of *Jatropha* have been planted with the involvement of State's Forest, Agriculture, Panchayat and Rural Development Departments. The state has the target to cover 1 million ha of land under *Jatropha* plantation. Ten reputed bio-diesel companies, including the UK-based D1 Oils, have offered to set up *Jatropha* oil-extraction units and to buy the produce from farmers in Chhattisgarh. Some of the Indian Companies like Indian Oil, Indian Railways and Hindustan Petroleum are also in the process of signing MoU with the state government.

Haryana: Farmers in Haryana have formed NGOs and cooperatives for promotion of *Jatropha* plantation. These NGOs and cooperatives are raising nurseries for *Jatropha* plantation and supplying saplings to others for further cultivation. They have been blending directly *Jatropha* oil into diesel fuel and successfully using this blend in tractors & diesel engines without any problem.

Rajasthan, MP, Orissa and other states: Apart from NGOs and state Government, the private companies are also promoting *Jatropha* cultivation by organizing practical demonstration, raising nursery, supplying seeds, seedlings and cuttings to farmers in their respective areas of operations.



Current Usages and Trials of Bio-diesel in India

Shatabdi Express ran on 5% blend of bio-diesel from Delhi to Amritsar on 31st December 2002.

Field trials of 10% bio-diesel blend were also done on Lucknow-Allahabad Jan Shatabdi Express.

HPCL is also carrying out field trials in association with BEST.

Bio-Diesel blend from IOC (R&D) is being used in buses in Mumbai and Rewari (Haryana) on trial basis.

CSIR and Daimler Chrysler have jointly undertaken a successful 5000 km trial run of Mercedes cars using bio-diesel as fuel.

NOVOD has initiated test run by blending 10% bio diesel in collaboration with IIT, Delhi in Tata Sumo and Swaraj Mazda vehicles.

Environment Protection Training & Research Institute, Hyderabad has been promoting by giving training to local NGOs, SHGs and others interested in the production of bio-diesel from *Pongamia pinnate* and *Jatropha curcas* in the state of Andhra Pradesh. According to Institute, the cost of production works out to Rs.16.00 per liter and is thus cheaper than diesel. Further, its byproduct in the form of cake can be used as manure/fertilizer. They have got the full training manual and the know-how.



3.3.8 Electravan and Battery operated Rickshaw

To combat increasing vehicle population the Bharat Heavy Electricals Ltd. Has developed ELECTRAVAN, is a smokeless, noiseless, oil free battery powered vehicle. It is run by an electric motor powered by a pack of rechargeable tract ion batteries positioned in the vehicle itself. The power transmission takes place through conventional gearbox and differential. The Speed is controlled by an electronic chopper controller and by changing the gears. In all other respect such as steering, braking, gear box and clutch arrangements, etc.

Electravans are similar to conventional diesel or petrol vehicles. Optional battery withdrawal arrangement is provided with facilities for removal of discharged batteries and fitting of charged ones within few minutes at the battery charging stations. In view of the advantages of Electravans to fight the menace of air pollution in urban and industrial areas, the Ministry of Non-Conventional Energy Sources (MNES), Government of India gives cash subsidy to the buyers.

Battery operated rickshaws are also being used on experimental basis, to demonstrate and promote efficient, pollution-free, and drudgery-free means of livelihood for poor people, who are working as daily wage earning Rickshaw pullers, by replacing the existing manual operated rickshaws in urban and semi-urban for short and medium distance means of conveyance.

Advantages:

- Freedom from highly discomforting noise and vibrations that are so common in diesel vehicles.
- Recurring savings of petrol or diesel.
- Ideal vehicle to keep environment clean.
- Ideally suited as public transport in congested areas, hospitals, factories, wildlife sanctuaries, airport, schools and places of historic importance.
- No engine related maintenance expenses and much lesser maintenance OPI chassis due to absence of vibrations.



Electravan



Battery operated Rickshaw



Application Areas:

1. Intra- City commuter service
2. Tourist resorts, bird sanctuaries, zoological parks.
3. Airport shuttle service
4. Government departments.
5. Industrial establishments, townships / satellite colonies.
6. Postal service
7. Mobile Banking Services
8. Milk delivery / grocery services
9. Golf clubs, schools, colleges / institutes welfare centers.
10. Courier service and mobile kitchen services.

3.3.9 Fuel Wood Plantation

The source of all energy on earth is the sun. The sun energy is trapped by the plants through the photosynthetic process and converts into woody portion, leaves, flowers, fruits, tubers, seeds, grains, nuts, oil seeds etc.

Animals and human beings obtain the same sun energy by consuming these plant products and absorbing them in the form of carbohydrate and fat (sources of immediate energy), protein (primarily for body building and growth but ultimately for energy during scarcity situations), vitamins and minerals (primarily for maintaining body resistance and facilitating body functions but ultimately for energy at the extreme cases) and water (which acts as a medium for all the physico-chemical functions in the body to transport energy and nutrients to different parts of the body and to excrete waste materials from the body).

All these are bio-chemical forms of energy. Fossil fuels such as coal, petrol, kerosene and other petroleum products are also extensively used as energy sources. These are also other forms of biochemical energy.

The woody materials of the plants have been the primary source of energy ever since man appeared on earth. About 70% of the energy needs in India is still met by fire wood, dried cattle dung and crop residues. Almost same is the situation in all South Asian countries and other developing countries of the world. For cooking and other household purposes in the rural areas fuel wood, cattle dung and crop residues are the main sources of energy. Among these three, the fuel-wood remains the most important source for the rural people and it will be so for many more years to come. Hence we should enquire into the possibilities of sustaining the fuel wood requirements of the rural people.

It is the women who are mostly concerned about the fuel for cooking. Daily they require minimum three to four kilograms of fuel wood for cooking. They spent many hours in the collection of firewood that is becoming more and scarcer day by day. This has a bearing on the health and family life of the women. In several villages, where there is not enough firewood the people burning cattle dung and crop residues as domestic cooking fuel. By burning dung they loose good organic manure and the soil loses the fertility due to use of chemical fertilizer, as other wise the dung could have been converted in to enriched & excellent organic manure by scientific composting for sustainable crop production.

The scarcity of fuel wood can only be solved by allotting land in all villages for fuel-wood and energy crop plantation in a scientific and systematic planning and peoples participation as a long-term strategy for meeting the fuel-wood requirement. This way every village can generate more than enough fuel wood for themselves as well as supply the fuel-wood to the nearest urban centers and earn sustainable livelihood for the entire village community and future generation. Plantation of appropriate trees would also improve the local ecology and regenerate the micro-agro-eco-system and conserve the environment. The planting of trees will also generate organic matter for the improvement of the physical and chemical properties of the soil protect erosion and washing away fertile top soil from and improve the water holding capacity of the entire village land.

Organizations

4 Local organizations managing sustainable energy

When new solutions are introduced, it is important that involved organizations, companies, and users are able to handle the new tasks they get. Often the best solution is to create a new local organization, formal or informal, to handle some of the new tasks. This chapter gives an overview of some of the most used and the most successful organizations and structures to manage local sustainable energy solutions in South Asia.

4.1 Planning and implementation of RET projects by Grameen Shakti in Bangladesh

Grameen Shakti (GS) uses short feasibility studies, reports from the field to plan and implement its projects. In many cases, short duration pilot projects are carried to test or fine tune an idea. For example, before opening a unit office on a new site, GS carries out a short feasibility study to find out the market potential of Solar Home Systems (SHSs) on the new site and whether it would be financially viable to open a new unit office there. Field staff focus on the following when carrying out their analysis: (i) no possibility of grid coverage in the near future (5 to 10 years); (ii) interested of people in SHSs; (iii) purchasing capacity of prospective buyers/customers; and finally (iii) total demand to ensure a operation of unit office on a sustainable basis, i.e. there would be at least 350 customers over the next three years.

Over the years, GS has developed in-depth understanding of the rural market. This has been achieved through continuous gathering of data through its wide network of field staffs and unit offices. These extensive data helps GS to develop new products and programmes as well as fine tune its existing programmes. For example, one of the surveys carried out by GS, showed that there was a potential market for new devices such as DC-DC converters, safety devices for black & white television sets, solar powered mobile phones, micro-utility models etc. Later, GS developed these products in response to client needs.

4.2 Communities & women involvement in RET implementation by GShakti in Bangladesh

Involvement of the local community is vital for the successful operation of Grameen Shakti (GS) renewable energy programme. Right from setting-up the GS gives local communities control over solar installations in their areas. This is achieved by GS working with teachers, community leaders and elected officials, who are explained the benefits of the solar home systems to the people they represent. Another important aspect of the local involvement is the manufacture, repair and maintenance of solar accessories close to the communities that are served by GS, by people who are familiar with their needs.

The main focus of GS is women who are always involved with its various programmes. For instance, women from end-user families have been trained as technicians by GS staff so that they can take care of the day-to day maintenance of their Solar PV systems.

From experience GS has learnt that it is more viable to train women than men as the men are in jobs outside their homes. Moreover, women technicians would find it easier to enter the 'End Users' homes when the only members available are women-folks as their men-folks are working outside their village. GS has also facilitated empowerment of women by providing them opportunities to earn their livelihood through business ventures such as solar powered mobile phones, home based poultry, handicraft businesses etc .

4.3 Solar Home systems & solar powered mobile Phones, Grameen Shakti

Grameen Shakti has taken up a project in coordination with Grameen Bank to provide modern telecommunication facilities in the rural areas. GS installed Solar Home Systems help to power mobile phones purchased by Grameen Bank members with loans from the bank.

GS took up the following activities to implement project: a) campaigns and grassroots level promotion to let the rural communities to know about solar powered mobile phone and its advantages; b) providing training facilities' to the users so that they can take care of their equipment; c) standard and up-to-date maintenance & repair services to ensure the good will of the users; and d) working in coordination with Grameen Bank.

Polli Phones or village phones have become very popular in the villages. At present more than 2,00,000 polli phones are operating in the villages. As a result of Polli phones a significant number of Solar Home Systems (SHS) have been installed in the villages because it offers stable and attractive income to them.

Nurjahan has installed a Solar Home System (SHS) in her phone booth to power her mobile phone. She is able to provide telephone facilities in an area where no such facilities existed before. She earns US\$ 3 per day from telephone fees. She also uses two lamps powered by SHS to keep her shop open after dark, thus extending her business hours and increasing business turnover. Thousands of women like her found socio-economic independence by generating income through solar powered mobile phones. Villagers are also enjoying better communication facilities increasing their business opportunities and standard of living.



Village ladies using SHS powered mobile phones

The applied technology is highly upgraded technology, but it is easy to use and maintain. One usually needs 50 W solar module with required number of 6 W fluorescent lamps and sockets for charging cellular phone batteries. The Solar Home System (SHS) has made positive contribution by reducing the expenditure on kerosene and health/medicine. After making full payment, there is very little additional costs. The costs are recovered (with in 3 to 4 years) by the income generated in a short time. Lamps can be used 4 hours per day, phones 8 hours per day. One can earn up to \$75 per month.

This intervention has been successful because it addresses a local problem and provides a solution which is easy to implement. It also ties appropriate technology with income generation and maximizes the benefit of the users. The intervention is also based on coordination with two or more entities who work together to serve their best interests. For example, Grameen Shakti (GS) is able to scale up its programme and increase the number of Solar Home Systems installed while the Grameen Bank (GB) is able to ensure more income generating opportunities for its members.

4.4 Trading methods and organizations in Sri Lanka

Sri Lanka Stoves Program has two different routes for dissemination of stoves. They are (1) The Commercial Route and (2) The Dissemination Route:

Commercial Route: In the commercial route there are 185 potter families distributed in 17 districts producing over 25000 stoves monthly. However almost 50% of the production is concentrated in one village consisting of 29 potter families who produce stoves in large quantities.

A survey revealed that nearly 65% of stoves sold to the traders are on spot cash 31% who had received a cash advance before and 3% were sold on credit. Many of the producers have regular dealers. However the producer dictates the terms since demand far exceeds the production level.



Wholesale Dealer

Modes of selling between producers and traders can be classified as below:

- Producers sell to wholesale dealers visiting the site.
- Producers themselves deliver to outside retailers directly
- Producers themselves deliver to wholesale dealers outside
- Small producers sell in the village f;
- Producers sell to the producer coop society.
- Producers sell to Producers who are also wholesale dealers

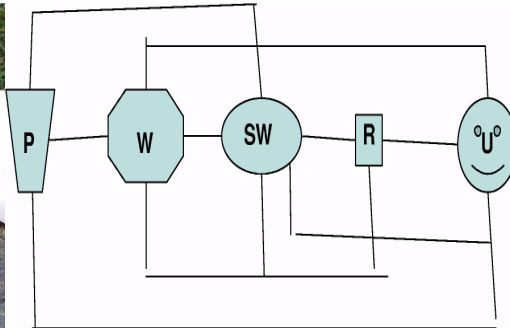

P= Producer U= User
W= Wholesale Dealer SW= sub wholesale dealer R= Retailer

In the case of small scale isolated producers where traders do not call over, the stoves are taken to the village fair and sold directly to the users. In places where the commercial route is operating stoves are bought from retail shops. However there are also street vendors who deliver the stoves to the user.

- Retail Shop
- Street Vendor
- Village Fair
- Wholesale Dealer

Dissemination Route: While the commercial route is mainly a traders affair, in the dissemination strategy, NGOs establish a revolving fund to facilitate the users who live in isolated areas who have no access to the commercial route to purchase stoves which are bought by the NGOs from either producers or traders and distributed to the users. Users pay the cost of the stove in installments. In the dissemination route, a small profit derived by selling the stoves is used to enhance the revolving fund to reach a wider group of users. If funds could be obtained from donors users are given stoves at subsidized price.



4.5 Self-Help Groups of women's for the promotion of Hh biogas plants in India

AIWC had been implementing household biogas plants, under the centrally sponsored, National Project on Bio-Gas Development (NPBD) of (MNES), Govt. of India, since 1994, as one of the Nodal Agencies for channeling funds (for subsidies, turnkey fees and trainings) to grassroots NGOs. The technical support was provided by a national level technical support organisation, who had developed the popular Deenbandhu biogas plant. This programme was conducted through AIWC branches in various states as well as other NGOs as partners.

AIWC had conducted more than 15-20 day bio-gas training programmes for the construction and maintenance of bio-gas plant and built over 10,000 plants.

- One of the branches of AIWC at Chunar, which is half way between Varanasi and Mirzapur in the state of Uttar Pradesh is working with nearly 800 women belonging to Self Help Groups (SHGs) providing training in various income generating trades like carpet weaving, pottery making, etc and employing them.
- This branch had taken up the AIWC NPBD programme and had implemented a very successful biogas dissemination and implementation programme, constructing 300 biogas units in this area. Since women were directly involved in this programme even after four years of implementation almost all the bio-gas units are being used by the end users, which has also created very big demand for construction of bio-gas plants.
- The husband of one of the beneficiaries "Laxmi" was running a poultry farm where they had around 150 birds in the big terrace in their house and through AIWC biogas programme they had built a 4 cum capacity unit in their backyard, which were fed with poultry litter and producing substantial quantity of bio-gas every day to all the needs of a joint family of 15 as well as their poultry farm workers. The pressure of gas was so high that at times they had to release the excess biogas it to reduce the pressure.
- Laxmi was happy with the biogas as now she doesn't have to use any other fuel in her house for cooking, but it has become a source of additional income for her, as she started supplying bio-gas to 6 to 7 houses nearby and charging them for the gas. She also had more surplus time and started working with AIWC branch at Chunar, which started giving her more self confidence. With the improvement of health due to reduction in indoor pollution as a result of use of biogas as a clean fuel for cooking, her standard of her life also improved, leading other women of the self-help group to follow her example, which created good positive impact on the socio-economic situation of the women in Chunar.

A group of women who are members of self help group (SHG) run by our partner NGO in Kakinada in Andhra Pradesh state have got their biogas units constructed under the AIWC bio-gas programme by taking the loans from their respective SHGs or building biogas. They have returned the entire loan with interest and are happily using their biogas, for cooking, lighting, and using the biogas digested slurry for their kitchen gardens and agricultural fields. There is great demand for more biogas units.



AIWC experience had been that wherever the women of the house had been trained in the use of biogas the correct way of feeding, maintaining etc. the units are always working well since the women have understood the importance & the benefits of using these bio-gas units. These two examples demonstrate that women SHG could provide one of organizational solutions for the effective means for promoting any affordable rural oriented RETs.

4.6 Village/User Cooperatives & Societies- Denmark experience that can be applied in South Asia

With cooperatives people are able to do things that they could not do alone. They can buy, sell, and process food and materials on large scale. They can employ people with skills they need. They can become independent of suppliers or services they find inadequate.

During the last century cooperatives have been crucial for the successful development of many of the richest countries of the world, such as the Danish farmer cooperatives that helped to establish Danish agricultural exports (Denmark is today the fourth richest country per capita).

Cooperatives can be crucial for activities that private investors will not invest in because the profits are too small.

The main types of cooperatives are:

- consumer cooperatives, where consumers own their shop, electricity provider, water supply etc. together (in some countries called consumer societies)
- producers' cooperatives, where farmers sell their products together, own dairies together.

Cooperatives are company structures, not social structures. They can involve poor people and make their development easier, but they do not necessarily bring new resources to end poverty.

In a cooperative each member pay an entrance fee (share) according to his or her needs for the service the cooperative provides and sometimes additionally gives a guarantee. Then the members can use the service and pay or receive money depending on the kind of cooperative. The cooperatives are either non-profit companies or pay their profit to the members of the cooperative according to the share or the actual use of each member. Often cooperatives are limited companies where the members can never loose more than their share + their eventual guarantee. In cooperatives the general rule is that each member has one vote.

Cooperatives have been important in development of energy supply, owning power plants, electric grids and many other supply structures that a family or a small company cannot afford alone. This is the case in many countries of the world. Energy cooperatives to reduce poverty can include:

- Village cooperatives that establish small hydropower & mini grid (see case from Sri Lanka).
- Village cooperatives to establish local power supply e.g. from wood gasification, engine, PV.



- Consumer cooperatives for maintenance, such as repair of PV and biogas installations.
- Farmer cooperatives that produce vegetable oil for transport (e.g. Jatropha oil) or bio diesel.
- Farmer cooperatives that produce fuel (e.g. charcoal briquettes) from agricultural residues

To work successfully, cooperatives must be adapted to the societies they are part of and they must have the necessary skills and facilities for the types of businesses they are doing. In addition they must have a leadership and a board of members that actively work for an efficient operation of the cooperative aiming at the highest benefits for the members.

Like any other business, cooperatives are not free from problems. Problems to look out for are:

- That the cooperative work as efficient as a good private company
- That the management does not take private benefits from the operation or give special benefits to some people. This has been a serious problem in areas where there is little experience with cooperatives or where the business morale for some reason degrades.



- That the conditions for the cooperative can change so much that the benefit of the cooperative for the members does not exist any longer. Then a restructuring is necessary, based in an analysis of the development and of the opportunities, and a general discussion among members.
- Dissatisfaction among members. To avoid that, cooperatives must have the maximum openness in its operations. Members must know precisely why they pay for. Further, they must have opportunities to suggest improvements.

How to form a cooperative:

- First there must be a need for the service that a cooperative can provide (such as lack of rural energy supply) and ideas to solve it (such a local energy supply)
- An overview of available legal structures is important, and then to choose the best available option (few lines about available structures in the four countries, such as the structure “limited cooperative” when it exist)
- A business plan that makes it clear to potential members what they get, what they pay and what they risk. The business plan should be based on best available information including experience from similar activities, eventual subsidies that can be given, etc.
- Information to potential members
- Creation of a list of interested members. Usually the cooperative can only be established if a minimum number of members join.
- Bylaws should be developed, usually based on existing bylaws from similar cooperatives
- A general assembly is the formal start of the cooperative. It also elects the board that starts the operations.

4.7 Decentralised power generation using solar PV system in remote Non-Electrified area, Operated and management by Producers-cum-Consumer cooperative- A case of Sagar Island, India

Sagar Island is a large island with an area of around 300 sq km spread over 43 villages and a population of over 1.60 lakhs, situated 110 km south of Kolkata. One of the main problems of the people of Sagar Island had been non-availability of grid electricity. Till 1996, there were only a few Diesel Generating sets with total capacity of 300 kW were providing electricity to a few selected 400 consumers, and too for a few hours in the evening. The operation and maintenance requirements of these generators were quite high and at the same time causing adverse environmental pollution.

In 1996, Sundarban Region was identified by MNES as one of the high priority area under its Solar Photovoltaic (SPV) Programme and gave necessary funds to WBREDA (West Bengal Renewable Energy Development Agency) for setting up of SPV Power Plants there.

As a result of MNES funding, in February 1996, the WBREDA set up and commissioned the very first 26 kWp SPV Power Plant at village Kamalpur in Sagar Island, with only 19 consumers.



At present many such power plants with aggregate SPV capacity of 300 kWp are in operation in Sagar Island providing electricity to around 2,000 households. These Power Plants have been set up with financial support from the MNES and the State Government, as well as soft loan assistance from the Indian Renewable Energy Development Agency (IREDA) under the World Bank assisted SPV market development programme.

At present, more than 50% of the total electricity consumed in Sagar Island is provided by solar energy generated electricity, through SPV systems, which also includes operation of essential services, like hospital services, water supply, etc.

The unique Features of SPV Programme at Sagar and Moushuni is that these SPV power plants are being run on commercial mode through the local rural co-operatives formed by the beneficiaries themselves under the aegis of WBREDA, catering to both the domestic & commercial needs for 5-6 hours in the evening daily. For obtaining a connection from the power plants, the end-user, is required to pay Rs.1,000/- as connection charge. Thereafter, each household (end-user) pays a monthly charges, ranging from Rs. 130/- to Rs. 1,300/-, which depends upon the connected loads, which are in the range of 100 to 1000 watts.

The distinguishing feature of the SPV decentralized power programme in both Sagar as well as Moushuni islands is the integration of power & water supply systems in these projects. The power plants have been designed to operate low cost conventional water pumps of average 3 HP capacity with an intelligent controller during daytime to provide drinking water without incurring any extra cost, except installation of some additional SPV modules. Around 700 families are getting the twin benefits of such integrated power & water supply systems at present in the twin Islands of Sagar and Moushuni.

This decentralized power generation venture utilizing SPV system, has opened up a new opportunities for meeting two basic needs of electricity and water together, of the dispersed population of the isolated & remote habitats having no alternate or traditional energy sources, in a meaningful way.

4.8 Village hydro power Consumers' Societies in Sri Lanka

In Sri Lanka, 65% of households have access to the national electricity grid. Majority of the rest use kerosene for lighting. Within the next 10 years, the total electrified may reach 75% of households. The government has implemented the renewable energy for rural economic development project (RERED) with the support of the World Bank and UNDP (GEF). This programme is implemented to promote the use of micro hydro, photovoltaic or biomass in households not serviced by the national grid. The main component of this project is a credit programme to provide medium and long-term financing for private project developers, NSOs and community cooperatives, so that the household electricity can be provided by renewable energy options. The project runs from 2002 to 2007.



Under this programme it is planned to install 90 schemes with a total capacity of 3762 kW ranging from individual capacities of 2.6kW to 40 kW to provide electricity to 3762 households. At end of Dec 2004, 31 micro hydro schemes were completed providing electricity to 1979 houses. The rest of the projects are in progress. At present it is estimated that nearly 250 off grid village hydro schemes are in operation in Sri Lanka.



One of the villages covered under this programme is "Waturawa" is a small village with a population of 250 people living in 45 houses situated in the Ratnapura District famous for gems in Sri Lanka. It is 10 km from the closest town and accessible by public transport. The main occupation of the villagers is agriculture. The national electricity grid is 4 km away and it is unlikely that the grid will be extended within the next two decades. The main energy sources in the village are firewood for cooking, kerosene for lighting and few using car batteries to watch TV. Each household spends about Rs 500/month to meet the energy needs. The village receives an annual rainfall of 4000 mm. The terrain of the village is hilly and a perennial stream runs through the village. This stream was exploited to provide electricity to the village. Since the houses are scattered, only 25 houses could be electrified. The electrification was carried out by IDEA as the project developer under the RERED programme.

After careful sensitization and building confidence of the village members, a consumer society was formed. The office bearers were trained to take on the appropriate responsibilities to run the project on a sustainable manner. Feasibility study and loan documentation were completed by IDEA. Processing of the loan took about 4 months.

After confirmation of the loan, each household was expected to contribute Rs 4000 (33 Euro) initially to the society funds and provide labour services on a voluntary basis in the construction of civil works and distribution lines. The electrical and mechanical equipment were made by local manufacturers trained by the ITDS. All unskilled labour for the civil works was provided by the members and carried out under the supervision of IDEA. The society was able to secure Rs 200,000 from the provincial council to meet the initial cost. The construction work was completed within a period of nine months. The society charges a fixed monthly fee of Rs 600 (5 Euro) from each household for the use of electricity. It is virtually the loan component payable by the society/member to the bank. The loan was released by the bank after the certification provided by a chartered engineer appointed by the bank, that took nearly six months after completion. The grant of SL Rs 400,000 obtained under the RERED project was invested in a bank and the interests received is maintained as a separate fund to meet the cost of maintenance and operations.

The society has managed the scheme in a very good manner for the last two years. There has been enough water throughout the year for continuous operation despite the drought conditions experienced in the dry season. The power generated is used mostly for lighting, ironing and watching TV. All the 25 houses have colour TVs and electric irons and refrigerators in 4 houses. Initially only CFL lamps were allowed but fused CFLs are often replaced with incandescent lamps due to high cost. Members are however requested to avoid the use of incandescent lamps, heating equipment and refrigerators during peak hours. During the day time the power is supplied to a 1.5 HP chili grinding mill.

The only major problem encountered has been the flooding of the power house, which costed Rs 20,000 for the repairs of the electrical equipment.

4.9 Micro-utility model in implementation of Solar PVS by Grameen Shakti in Bangladesh

Only 30% of the Bangladeshi people have access to grid electricity and most of them live in the cities. There cannot be any economic development without electricity. Because of this, rural communities suffer from under-utilized economy and depressed business activities. Mobility of people is also hampered after dusk due to security problems. However many people cannot afford Solar Home Systems individually. This is one of the barriers to the scaling up GS solar programme and revitalizing rural economy through the use solar PV technology, that many people cannot afford Solar Home Systems individually.

The Grameen Shakti's "Micro-utility model" Solar Energy Programme has been initiated to address these vital issues of extended business hours for increasing business turn-over. The GS's "Micro-utility model" scheme is meant.

GS has therefore, developed this special programme to make it easier for those who cannot afford SHSs individually and to become owner of one. Under this programme, GS facilitates a group of people to share the cost and benefit of using a Solar Home System (SHS). This programme is based on ownership model because this ensures individual responsibility. The purchaser of the SHS is considered the owner of the system and is responsible for re-paying installments to GS.

The due amount is paid to GS by renting his lights to other people especially to his/her neighbours. This scheme especially targets the petty shop keepers in rural and semi urban areas, which are not connected with grid electricity.

GS took up an intense promotional campaigning among the shopkeepers to popularize this model. The GS also developed an attractive package to create interest among the shopkeepers community to make them owners of SHSs under this model. Under this scheme, the entrepreneur or the prospective owner of SHS does not have to pay any service charges and gives a small initial down payment of only 10% and gets his SHS installed. By regularly paying his installment, he would become the owner of the SHS in three and a half years. This strategy yielded the amazing results and thus Micro- utility model has become extremely popular among the shopkeeper's community.

Till date, more than one thousand SHS's have been installed under this scheme. This model of implementation has helped GS to tie solar PV technology with income generation, thereby bringing the greatest benefit to its end-users. This has also helped GS to scale up its programme by reaching those who cannot afford a SHS individually- GS has thus able to install more than 2000 SHSs.

One such shopkeeper Mr. Umor has a grocery shop at Kormal bazaar. He has bought a solar home system with six lamps. He is using one lamp himself and renting the other lamps to neighbouring shops for a fee of 7 cents per night/ lamp. In this way he has increased his income and the income of the neighbouring shops.

The growing and striking impact of Micro-utility model is that it has increased business turnover and extended business hours in rural bazaars. Now shopkeepers can afford pollution free, efficient lighting at minimum costs and keep their shops open after dusk- thus more business. Customers also enjoy greater mobility- freedom and can come to the markets after dusk.



Micro-utility Model in a market place

There is reduced health risk and less danger of fire because kerosene lamps are not being used. Women also enjoy greater mobility and freedom because their security is increased due to better lighting system. The applied technology is highly upgraded one but easy and people friendly. After making full payment, there is very little additional cost involved. The capital cost of SHS is recovered in 3-4 years. Lighting is available for almost 4 hours per day.

4.10 SPV Lanterns for mobile food stall by poor couple for income generation, AIWC, India

Elliot Beach in Chennai.-Madras The "Other" beach of the city- as against Marina, to the north is becoming increasingly popular as the evening destination of the people, especially from the nearby residential areas, Of late, a number of small stall have sprung up, which function in the evenings, from about 6 pm to 10 pm selling small eats- chilly cutlets, wafers, etc, and some offering amusements like shoot the balloon, darts etc. In the beginning about 20 of these stalls used solar lanterns.

Chandran and his wife, who are residents of a nearby fishing village, run a vegetable cutlet stall. They have two lights which they take from a nearby house. An enterprising person there had purchased about 24 Solar lamps, takes an advance of Rs. 100/- per light and Rs. 10/- per light per day after 10 pm they return the lights to the owner who gets them charged for the next day, keeps them ready for use in the evening.

Chandran and his wife make about Rs.50 to Rs.75 on week days and Rs.100 to Rs.150 on the evenings of week-ends. They have no problem in paying the one time deposit of Rs. 100/- and the daily charge of Rs.10/-per light. They say the Solar lamps give light for a little more than 4 hours and functions well, which is enough for them. They do not have to buy Kerosene for the petromax lights they were using earlier, and they don't have to buy those lights or spend a lot of time cleaning them. Their hands also used to smell of kerosene, which was not relished by the customers! And the solar lights are not "hot" to remain closer to it. They are very happy with the solar lights. It not only prevents kerosene pollution on the beach but also proves profitable to the enterprising persons who rent them out on daily basis. Now 3 years later there are hundreds of Solar Lanterns being used along the beach and it is a beautiful sight to see in the evenings.

4.11 Role of Rural Energy & Ecological Volunteers Corps (REEVOCs) in RE promotion India

The village level volunteers group, called as REEVOCS (Rural Energy and Ecological Volunteers Corps) has played an important role in the implementation and management of renewable energy (RE) programmes in 12 Eco-villages. These villages are being jointly promoted and developed by WAFD and INSEDA under the "eco village development projects", since April 2002.

The last 4 ½ years of experiences in the "eco village development project" has shown that unless a community has ownership of a programme and is involved at all levels from planning, implementing, monitoring and evaluating, long term sustainability is not possible. The EVD project being implemented in 12 villages of Sewar Block in Bharatpur District of Rajasthan state, has successfully demonstrated this.

The steps followed in this process are summarized below:

- A group of 4 volunteers were selected from each village, 2 men 2 women making a total of 48 volunteer group, called as REEVOCS;
- For 2 years this group (entire 48 volunteers) met at least once a month and learnt about the importance of eco village development and it's relevance in today's world, and the important role that renewable energy plays in this; and
- It is important to target each important group in the village, to achieve this, these volunteers helped promote and organize, in their villages, women's groups and youth groups, and carried out implementation and demonstration of among other things renewable energy units.

After four years of implementation these volunteers (REEVOCS) have understood the importance of eco village development, and the role of renewable energy such as biogas plants, plantation of energy crops like Jatropha, and solar energy. In addition they have also become aware about the production of SVO (straight vegetable oil) and bio diesel from non-edible oil seed like Jatropha seeds for operation of diesel pumping sets, as well as decentralize power generation at the rural household and village levels, by using bio-diesel operated generating sets. They are now motivated to undertake Jatropha cultivation on the boundaries and their other wise unproductive waste lands.



Now for more systematic and organized implementation of RE and other related activities in an integrated manner for desired output/results in a foreseeable future, the 48 REEVOCS have formed a "management committee".



This “management committee” has been elected by the volunteers themselves which has one representative from each of the 12 project villages. The management committee in turn has elected 6 office bearers- out of them three are the key office bearers, i.e., President, Secretary and Treasurer, to oversee the day to day operation aspects of the programmes in these 12 eco-villages. The other office bearers are, Vice president, Joint Secretary and Joint Treasurer. The office bearers take more responsibilities on behalf of the management committee and meet more frequently during the inter-sessions of the management committee meetings and are delegated to meet the district level government functionaries to present the problems of the group as well as find out appropriate government programmes to implement in these 12 villages.

The role of this management committee is to sit with WAFD and take an active part in planning, implementation, evaluation and monitoring of the programmes, which will have focus on community-centered poverty reduction, by integrating REs in all the socio-economic developmental programmes. Field level monitoring and decision-making is done much more effectively by the committee. Solutions to problems are found by the committee jointly, which are cost effective as well as much more realistic and field oriented.

Role of WAFD is that of a facilitator and to for providing guidance where needed, as well as to arrange for funds, training, RE, demonstration and mobilize appropriate technical support.

To further ensure people’s active participation, self help groups or user groups and micro-credit groups are being promoted for different activities, such as user group for bio gas plant owners, user group for kitchen gardens etc. These user groups will further help the managing committee in monitoring, evaluation and promotion of their specific programs/activities.



To sum up, village level management of programmes through people’s own committees and organizations will ensure sustainability and continuity of the programme.

Over time a knowledge bank will be created within the people themselves, and they can take care of most of their problems. External dependence will be reduced in terms of dissemination of new findings and information etc, from time to time.

With experience the group will be able to independently access certain funds from government and other sources as well.

4.12 Role of Private Sector in the Promotion of Sustainable Energy Technologies in Nepal

Nepal is a mountainous country with rugged terrain and several perennial streams, rivulets and rivers. In the mid and high hills of the country, Traditional Water Mills (TWM) or *Ghattas*, are located on the banks of these water sources that- for centuries- have been part of rural communities and are used as an important energy source for grinding cereals. As per an estimate 25,000 to 30,000 mills are in operation in the country, one unit typically servicing 20- 50 households. Because of their low efficiency, the traditional water mills are hardly able to cope with the increasing food-processing needs of the local communities, resulting in to their place is be taken over by the diesels powered mills, and to a lesser extent micro hydro mills. These modern mills are neither environmentally benign nor sustainable as they use imported machinery operate on diesel fuel, which drains the countries foreign exchange and creates atmospheric pollutions.

An Improved Water Mill (IWM) has been developed that has almost double the efficiency of the traditional water mills and also improves performance as well as reliability without changing the traditional management system. The improved water mill technology is a modified version of the traditional water mills designed on the principals of Impulse Turbine.

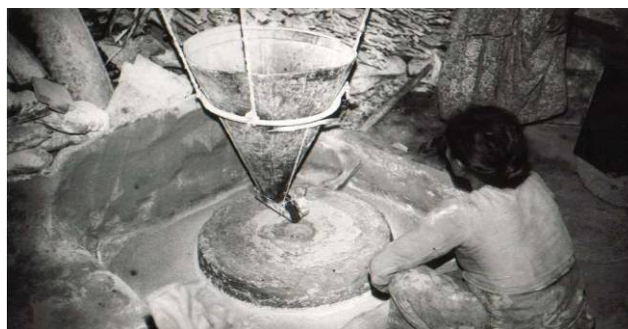
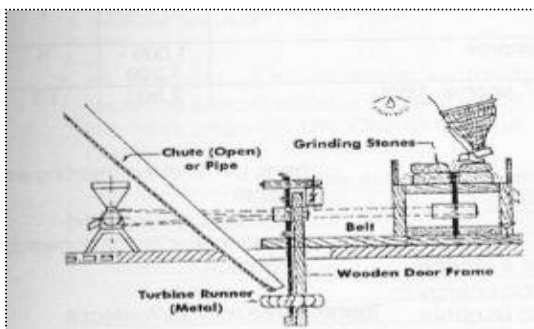

Improved Water Mill for Multiple Application (Operation for Grinding on the right)

The technology has a direct impact as it can be used for a longer period into dry season and through their increased energy output- the quality of the milling services offered to the local community improves. The improved service quality is translated into a higher agro processing capacity (milling capacity often doubles) and/or diversified range of services (hulling, oil expelling, saw milling etc). An IWM also generates electricity for remote villages contributing to the quality of their livelihood.

The history of IWM development in Nepal dates back to 1984, when the German Appropriate Technology Exchange of the German Technical Cooperation (GTZ/GATE) initiated a programme aiming for dissemination of IWM. From 1990 onwards the Centre for Rural Technology, Nepal (CRT/N), with the assistance of GTZ and other development organisations, has actively involved in the promotion and dissemination of IWM through supporting traditional Ghatta (Water Mill) owners for improvement.

IWM Program has adopted approaches that lead towards making the program sustainable. It has emphasized for active collaboration and participation of private-public sector partnership on the basis of their comparative advantage regarding different aspects of the programme.

The focus has been given for the effective institutional linkages among the program partners such as Centre for Rural Technology, Nepal (CRT/N) as implementing agency, Alternative Energy Promotion Centre (AEPIC), the government's wing for the promotion of alternative energy and executing agency of IWM program, SNV/Nepal representing the donor, development organizations involved in the promotion of the technology, Service Providers, Water Mill Owners and its Users.

The private sector organizations, including the NGO has been playing key role in the effective delivery of quality services for the promotion and dissemination of the technology in Nepal. Major Private Organizations involved for the delivery of various services in the programme are as follows.

- CRT/N is the lead organization responsible for the implementation of the whole programme. Within the framework of the programme, CRT/N has worked closely with government agencies, donors, development organizations, I/NGOs, private sector organizations and service providers etc. for its smooth implementation.
- IWM Service Centres are private sector entity, pre-qualified by the programme to work at the local level, and are key actors in delivering socio-technical services required by the mill owners. Presently 16 IWM Service Centres are working in 16 districts, one in each district. They are responsible for inventory of water mills in programme districts, social mobilization, Water Mill Owners' Group/ Association formation, Orientation/Demonstration organization, feasibility survey, procurement of IWM components from manufacturers, linking with micro-financing institutions to facilitate credit support to interested mill owners, installation of IWMs and providing after sale services.

- Private workshops and manufacturers are responsible to produce standard kits suitable for various end use purposes as per required by the mill owners. Presently there are 8 manufacturers pre-qualified by the programme for ensuring the supply of quality products. The quality of the products is checked and controlled by CRT/N.
- The Micro-finance Institutions (MFIs) are also key players, responsible basically to administer credit support to interested mill owners in coordination with IWM Service Centres, though MFIs are still not so organized on the delivery of required credit to the millers. Therefore, at present, the IWM installation is mostly done through self-financing by the millers themselves with some subsidy support for the installation activities.
- Water Mill Owners' Association works mainly as a pressure group for the rights of the mill owners and for awareness campaign among the millers and users not only for IWM promotion but also for social and income generating activities linking with other renewable energy. Some associations are also working as IWM Service Centers and MFIs
- Local Blacksmiths are available at the local level for the supply of spare parts required for regular repair and maintenance of the technology.
- There are institutions that undertake various programmes related trainings, studies and assessments, publication related works etc. Their role has been useful in the local capacity building through skill and entrepreneurship development and potential end use diversification.

All the private partners have been playing their respective role in an effective manner to make the programme a success. But all the key actors are inter-dependent for effective delivery at the end users level.

Sketch below highlights the institutional linkages of private- public sector collaboration.

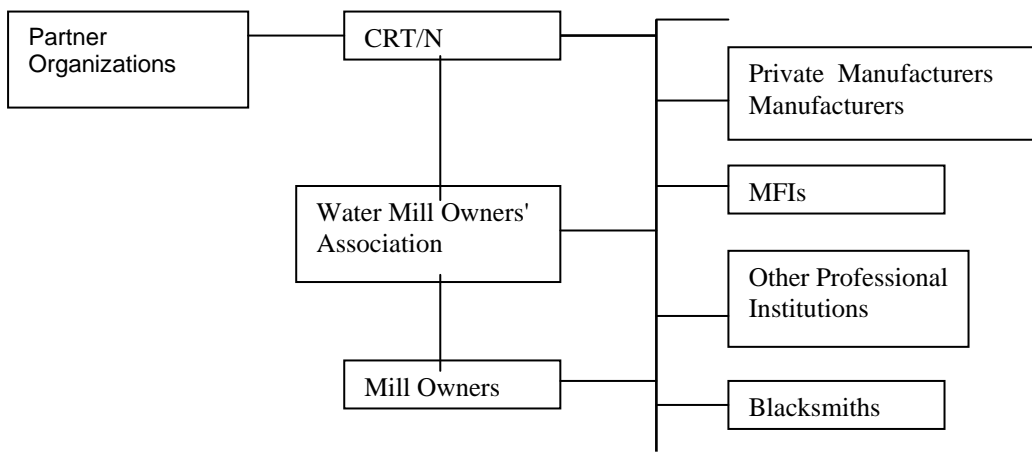

4.13 Solar Home Lighting (SHL) through women's SHGs in Alwar dist, Rajasthan by SOHARD, India

Balaheer village belongs to Neemrana block, and lies to the north-western corner of Alwar district in Rajasthan. Balaheer is a part of the neighbouring Nangli village, hence popularly known as Nangli Balaheer. It's a medium-sized village having a population of 850 people.

Electrification of Balaheer village was a distant dream that meant acute problems for the community due to lack of power and electricity supply resulting in numerous problems and more so for the school going children and women.

SOHARD has installed a total of 44 solar lighting systems to 44 families on equal financial partnership with the SHG's. Following strategy was used for implementation, which led to success:

- Focused on rural women, especially of deprived and marginalized sections of the society.
- Rapport building with the village community, through active collaboration with the women Self Help Groups (SHGs).



- Ensuring community participation in the programme by motivating and convincing them to contribute at least 50% share from the villagers for the purchase of SHL system.
- Devised proper mobilization- education, capacity building processes and follow-up mechanism for minimum one year for analyzing success and sustainability of the Project.



Providing the solar home lighting system (SHLS) through SHG's has resulted in empowerment of the women members of SHG, who were completely involved in the process. Some of the direct benefits of the SHLS provided to SHG members were improved performance of their children in studies, due to un-interrupted and pollution free lighting systems during the night, generation of additional income. Solar Lighting Lamp project progressed due systematic mobilization of people at the village level and their active participation.

4.14 Empowering rural poor women by enhancing income through biogas plant by WAFD, India

When WAFD (women's Action For Development) moved its development programmes to Bharatpur district in mid 1990's, with its various activities to empower the rural women, adolescent girls and children, it realized the wide potential for biogas plants as an environmentally sound renewable source of sustainable energy. Most of the villages had cattle but the dung was being used mostly for burning as fuel or for making organic manure in traditional and inefficient manner, by just allowing the dung to gather in a heap till required. The WAFD's biogas construction team with the technical guidance and assistance of the present Secretary General (SG) of INSEDA, who is one of the designers of the Deenbandhu biogas plants (DBP), has constructed over 300 DBPs plants under the aegis of the NPBD of MNES, first through the state nodal agency, NPBD funds routed through the district authority; and subsequently, through a national level NGO nodal agency.

However, in a few years WAFD realized that while the women were the beneficiaries of the biogas plant, the decision makers were men and the biggest gainer. The decisions to invest in the building of plants came from men if they could be convinced that biogas digested slurry (manure) was good for their agriculture, as they were not interested in its cooking value or removal of the drudgery of women by providing them clean and convenient fuel at their door step, using the cattle manure. This was due to the lack of critical awareness and concern on these important issues. Therefore WAFD realized that the real benefit of biogas, as an important tool for development and empowerment could only become a reality if the women in the WAFD target villages could somehow take the role of financial decision makers as well as actively participate in the implementation of biogas plants along with the men.

Another important consideration by WAFD in the selection of new biogas model design would be the utilization of locally available building materials and local skills to a maximum extent possible to provide livelihood to the rural landless labourers, and more specifically the women. At the same time to bring down the cost of the biogas plant so that it becomes within the reach and means of those poor people who had the required number of cattle to operate the smallest viable size of 1 m³ capacity and next higher size plants 2 m³ capacity.

Based on the participatory assessment of the local situation, WAFD also recognized that in order to involve rural women in an effective manner, there has to be any activity which would broadly address the issue of sustainable livelihood. Therefore the most appropriate biogas model would be that, which apart from addressing other issues mentioned above, would also provide income to them, either through employment or self-employment in their own villages as well as provide additional income either during off-season or in their spare time as per their convenient would be more acceptable to them and their families.

Thus the dialogue of WAFD with the present Secretary General (SG) of INSEDA (who is also the Regional Coordinator of INFORSE South Asia), who was also one of the designers/developer of the Deenbandhu biogas model, led to the designing of the present Grameen Bandhu Plant (GBP) by him in mid 1990's. The Grameen Bandhu Plant (GBP) is a bamboo reinforced cement mortar (BRCM) model and uses bamboo as the main building materials. The environmentally-benign and ecologically sound bamboo grows very fast, which is either available in villages or suitable species can be prorogated in the local area or can be purchased form the nearby areas. Thus we were able to completely eliminate the ecologically damaging & environmentally polluting bricks, with bamboo as main building material for plant construction.



As a first step WAFD decided to build only three GBP models using its own funds and resources, under the technical guidance of the SC, INSEDA, with three cooperating farmers in one of the WAFD's target villages in Bharatpur district, in 1996. During the construction of this model he also got two of WAFD master masons (MM) trained, so that when in future farmers were convinced and ready, these MM would be used for implementation/construction of GBP.

All these took both WAFD and INSEDA almost two years when we were finally ready with a practical field worthy GBP design with appropriate modifications. The GBP was also comparatively cheaper than the existing most popular Indian fixed dome plant made from brick, and called as Deenbandhu plant (DBP), and was equally strong and sturdy. The response of the plant owner and the local people and others who visited was very positive.

Due to three years of continuous failure of monsoon, Bharatpur district was having draught and farmers were barely able to take one crop in the winter season (Rabi crop season). This had affected these landless agricultural labourers, as both male and female, who mainly depended on sowing, and harvesting of agricultural crops and fodder collections for their 1-2 milch animals (buffalo) had no regular jobs. Some of the male youth with minor skills had migrated to urban centers and big cities. Therefore, WAFD and INSEDA found this an ideal situation to test and asses the benefit of the new biogas model (the Grameen Bandhu model) as a tool for providing employment to poor people, including local artisans and women.



As mentioned, an important innovation for the construction of bio gas plants, using bamboo reinforced cement mortar (BMRC) of 2 cubic meter (2 m³) capacity had already been experimented and field tested jointly by WAFD and INSEDA with 3 farmers in one of the villages, for over 6 years now since 1996. The response of end users (owners) and the local villagers about new model was also very positive. The use of bamboo baskets had brought down the price of this biogas plant christened as Grameen Bandhu (meaning friend of the rural people) so that it was at least 15% cheaper as compared to the existing most popular fixed dome plant, the "Deenbandhu model", while also ensuring the participation of women in the weaving of bamboo structures for constructing this model.



When WAFD and INSEDA had secured funds for building a few demonstration-cum-training Grameen Bandhu plant (GBP) in the year 2002, we discussed and debated as to how best to associate women from the poor landless households. Initially there was mixed response- how these illiterate and unskilled will make (weave) bamboo structures as per the dimensions of the plant? What will happen if bad workmanship will fail the plants built at farmer's field?

The participation of women in the fabrication/weaving of bamboo structures one of the considerations, so that they could also earn wages by weaving bamboo structures with in their own villages, for the construction of this biogas model. In fact WAFD & INSEDA also recognized this while designing the GB model, to ensure effective involvement of women in building it.

Starting from December 2002/January 2003 a number of practical trainings on step-by-step building of Grameen Bandhu model were conducted for local project staff, technicians, artisans and the local village level volunteers, as a group known as REEVOCs (Rural Energy and Ecological Volunteer Corps). Above all the training of the women of the landless agricultural families, in one of the WAFD target villages (Nagla Banjara) was the watershed in the involvement of these women as active partners in the implementation of this new innovative, low cost and affordable household biogas model. During the 15-21 days practical training women were given enough stipends to maintain themselves and meet their daily needs. The important thing has been that all these trainings for women weavers were held in their own villages, some of them with very small siblings were able to attend the training, as due to three years of draught they needed the job and money and it was the period of year when there were no earnings from the agricultural operations. Ten selected local women from the landless families were trained in the first training. 20 village women wanted to be trained, but to impart better training and maintain the quality of supervision during weaving only 10 were selected, as these woven bamboo structures had to be used for construction of GBP at the farmers field who were also contributing 60% of the cost of their plants, and the guarantee of trouble-free operation was provided by WAFD.



Twenty women from Nagla Banjara have been trained and re-trained to weave the bamboo baskets while one man (REEVOCs) from the same village has learnt how to guide them in measuring when they start the weaving in the underground moulds (pits). The women of Nagla Banjara now weave the bamboo baskets and other woven bamboo structures to be used as reinforcement for the and every year they are able to get at least 2-3 months of work and earn a small amount of Rs.1000/- per woman. From Nagla Banjara the bamboo baskets and other woven bamboo structures are transported to the site of the construction of the Grameen Bandhu plant (GBP). The bamboo having a long life and flexible material for construction ensures that the final biogas structure has a long life if basic and routine care is taken.

In the absence of any government subsidy, and to overcome this problem we are studying the possibility of granting small loans to the women on special rates of interest for the construction of bio gas plants.

While WAFD and INSEDA trained these landless women from Nagla Banjara initially for building Grameen Bandhu plants, but one of the spin-offs was when we decided to build our training-cum-demonstration, roof-top harvesting system- the same women were utilized for building BRCM storage tank, earning wages. Thus, we have demonstrated that women can play an effective role and also perform the jobs requiring technical-skill and also earn their livelihood through the renewable energy implementation activities, only if we have to keep women in the focus while designing any new technology.

Annexure- A

A1: Information on energy contents, conversion and light efficiency

Energy Contents			
Wood	4.5	kWh/kg	Dry soft wood with less than 15% moisture. Hard wood: 15% higher
Dung	3	kWh/kg	Dry dung cake, wet dung lower
Straw	4	kWh/kg	Dry straw from cereal
Charcoal	7	kWh/kg	Typical
Kerosene	10	kWh/ltr	
Diesel	10	kWh/ltr	
Petrol	9	kWh/ltr	equal to about 12 kWh/kg
Gas (LPG in bottles)	12.7	kWh/kg	
Coal	6	kWh/kg	Hard coal, typical. Brown coal and lignite are lower

Conversion factors	
1 kg oil equivalent	10kWh
1000 Btu (British thermal Unit)	0.293kWh
1 MJ (Mega Joule)	0.28kWh

Various sources of light for use in a village									
Light efficiency and consumption, typical	Wick lamps	Hurricane lamps	Pressure lamps	Gas lamps	Light bulbs (incandescent)	Halogen lamps	LED (white)	CFL lamps	Light tubes
Efficiency, lumen/w	0.1	0.15	1	1	6-18	14-25	22-38	40-60	50-60
Efficiency, relative	0.2%	0.3%	1.7%	1.7%	10-30%	23-40%	37-63%	60-100%	80-100%
Light given (lumen)	15	30	1400	200	500	400	100	550	1800
Power consumption (Watt)**	150	200	1400	200	40	20	3	9	36
Consumption, 4 hrs*	0.06 ltr k.	0.08 ltr k.	0.56 ltr.k.	0.13 m ³ b.	0.16 kWh	0.08 kWh	0.012 kWh	0.036 kWh	0.14 kWh

* 4 hours are typical daily consumption for most lamps for household use, k=kerosene, b=biogas with an energy content of 6 kWh/m³

Sources: ESD - <http://www.eurorex.com/ugtoges/light.htm>, and Danish information on efficient lighting

** The power consumption are examples, other wattages are also available for most lamps

A2: Examples for Chapter 2.2 – 2.5

Present energy consumption	families	Use/family		Use/year	Energy content	Energy use/year
	number	kg/day	kg/day	kg/year	kWh/kg	kWh/year
Families in village	50					
Wood	50	4	200	72000	4.5	324000
Dung	30	2	60	21600	3	64800
Agri-waste/Straw	25	1	25	9000	4	36000
Gas bottles (14,5 kg/bottle)	5	0.04	0.2	72	12.7	914
	families	no./month	Use/month	Use/year	kwh/battery	kwh/year
Batteries D-Size	50	2	100	1200	0.025	30
Batteries AA-size	50	2	100	1200	0.005	6
Grid electricity use	families	kWh/month	kWh/month	kWh/year		kWh/year
Household use	5	25	125	1500		1500
		kWh/month		kWh/year		kWh/year
Clinic & office		75		900		900
Village grinder				400		400
Oil/kerosene use	Number	ltr/family/month	ltr/month	ltr/year	kWh/ltr	kWh/year
Household kerosene	45	2	90	1080	10	10800
Village grinder				1000	10	10000
Tractor	1			6000	10	60000

Costs of various energy forms

Batteries, D-Size	20Rs/piece	Local*	25%	Bought**	100%
Batteries, AA-Size	15Rs/piece	Local*	25%	Bought**	100%
Grid electricity	12Rs/kWh	Local*	0%	Bought**	100%
Firewood	1Rs/kg.	Local*	100%	Bought**	10%
Dung, agri-waste	non, it is not sold	Local*		Bought**	0%
Bottled (LPG) gas	20Rs/kg.	Local*	0%	Bought**	0%
Kerosene	25Rs/ltr	Local*	0%	Bought**	100%
Diesel	25Rs./ltr	Local*	0%	Bought**	100%

* Fraction of income that stays in village as profit, payment for collection of wood etc.

** Fraction of fuel that is bought, the rest is just collected and used without payments

Division of electricity consumption into end-uses

Electricity (kwh/y)	Light	Radio/TV	Refrigerator	Grinder	Water pump	Total	Costs
Batteries	18	18				36	42000
Households with grid*	1168	332				1500	18000
Clinic etc.	500		400			900	10800
Agriculture (grinder)				400		400	4800
Total	1686	350	400	400	0	2836	75600

* Light for households with grid: Each household has in average 4 lamps 40 W each used 4 hours/day



Energy Balance Present situation	Fuel (kWh/year)				Electricity	Total	Efficiency		End-use (kWh/year)
	Wood	Dung/waste	Gas	Diesel/kerosene.			Fuel	Electricity	
in kWh/year						All source			
Stove, type 1 (wood)	324,000					324,000	12%		38,880
Stove, type 2 (dung/waste)		100,800				100,800	11%		11,088
Light				10800	1,686	12,486	0.3%	12%	235
Radio/TV					350	350		50%	175
Refrigerator					400	400		50%	175
Village grinder (agriculture)				10000	400	10,400	15%	60%	1740
Water pump						0			0
(other)			914			914	50%		457
(other)						0			
Tractor (agriculture)				60,000		60,000	20%		12,000
Total	324,000	100,800	914	80,800	2,836	509,350			64,750
Costs	7200	0	1440	202000	75600	286,240	Rs/year		
Cost/household excl. Agri.	144	0	29	540	1200	1,913	Rs/year in average		
Costs that stay in village	7200	0	0	0	8400	15,600	Rs/yr that stay in village**		
Work in village	100	30	0			130	Work in hours/day***		
CO2-emissions							CO2 emissions kg/y		

Tables for chapter 2.3

"Business as usual" future energy consumption	families	Use/ family	Use/day	Use/year	Energy content	Energy use/year
		kg	kg/day	kg/year	kWh/kg	kWh/year
Wood	50	4	200	72000	4.5	324000
Dung	30	2	60	21600	3	64800
Agricultural-waste/Straw	25	1	25	9000	4	36000
Gas bottles (14,5 kg/bottle)	5	0.04	0.2	72	12.7	914
	families	no./month	Use/month	Use/year	kwh/battery	kwh/year
Batteries D-Size	50	1	50	600	0.025	15
Batteries AA-size	50	1	50	600	0.005	3
Grid electricity use	families	kWh/month	kWh/month	kWh/year		kWh/year
Household use	50	25	1250	15000		15000
		kWh/month		kWh/year		kWh/year
Clinic& office		75		900		900
Village grinder				400		400
Water pump		30		360		360
4 street lights, 50 W, 12h/d.		72		864		864
Small cold storage, 1 kWh/d		30		360		360
Oil/kerosene use	Number	ltr/family/month	ltr/month	ltr/year	kWh/ltr	kWh/year
Household kerosene	0	2	0	0	10	0
Village grinder				1000	10	10000
Tractor	1			6000	10	60000



Division of electricity consumption into end-uses							
Electricity (kwh/y)	Light	Radio/TV	Refrigerator	Grinder	Water pump	Total	Costs
Batteries	18	0	0			18	21000
Households with grid	11680	3320	0			15000	180000
Clinic etc.	500	0	400			900	10800
Agriculture				400		400	4800
Common facilities*	864		360		360	1584	19008
Total	13062	3320	760	400	360	17902	235608

* In this case street lights, cold storage, water pump

Future "Business as usual" energy balance	Fuel (kWh/year)				Electricity	Total	Efficiency*	End-use (kWh/year)	
	Wood	Dung/waste	Gas	Diesel/ker.					
kWh/year					All sources	Fuel	Electricity	All energy	
Stove, type 1 (wood)	324,000				324,000	12%		38,880	
Stove, type 2 (dung/waste)		100,800			100,800	11%		11,088	
Light				0	13,062	13,062	0.3%	12%	1,567
Radio/TV					3,320	3,320		50%	1,660
Refrigerator					760	760		50%	380
Village grinder (agriculture)				10000	400	10,400	15%	60%	1,740
Water pump (other)					360	360		75%	270
(other)			914			914	50%		457
(other)						0			
Tractor (agriculture)				60,000		60,000	20%		12,000
Total, energy	324,000	100,800	914	70,000	17,902	513,616			68,043
Costs, total	7,200	0	1,440	175,000	235,608	419,248	Rs/year		
Cost/household, excl. Agr.	144	0	29	0	4,616	4,760	Rs/year per family in average		
Income in village	7,200	0		0	4,200	11,400	Rs/yr that stay in village**		
Work	100	30				130	Work in hours/day***		
							CO2 emissions kg/y		

* Electric efficiencies are relative to best available technology.

** It is estimated that 20% of battery costs are going to local shop/seller in the village

*** It is estimated that it takes 1/2 hour to collect one kg firewood and 1/2 hour to collect and dry one kg cow dung



Tables for chapter 2.5

Future "pico-hydro -chulha" energy consumption	families	Use/ family	Use/day	Use/year	Energy content	Energy use/year
		kg	kg/day	kg/year	kWh/kg	kWh/year
Wood	50	2.7	135	48,600	5	218,700
Dung	0	2	0	0	3	0
Straw/Agri-waste	0	1	0	0	4	0
Gas bottles (14,5 kg/bottle)	5	0.04	0.2	72	13	914
	families	no./month	Use/month	Use/year	kwh/battery	kwh/year
Batteries D-Size	50	1	50	600	0	15
Batteries AA-size	50	1	50	600	0	3
Picohydro-electricity use	families	kWh/month	kWh/month	kWh/year		kWh/year
Household use	50	10	493	5,912		5,912
		kWh/month		kWh/year		kWh/year
Clinic & office		42		500		500
Village grinder				3,600		3,600
Water pump		30		360		360
4 street lights, 15W, 12h/d.		22		259		259
Small cold storage		30		360		360
Oil/kerosene use	Number	ltr/family/month	ltr/month	ltr/year	kWh/ltr	kWh/year
Household kerosene	0	4	0	0	10	0
Village grinder				200	10	2000
Tractor	1			6000	10	60000

Division of electricity consumption into end-uses

Electricity (kwh/y)	Light	Radio/TV	Refrigerator	Grinder	Water pump	Total	Costs
Batteries	18	0	0			18	21000
Households with grid	2628	3284	0			5912	
Clinic & office	25	0	475			500	
Agriculture				3600		3600	
Common facilities*	259		360		360	979	
Total	2930	3284	835	3600	360	11009	

- In this case street lights, cold storage, water pump

Investments "pico-hydro.." Pieces Costs Loan Subsidy Cash

Pico-hydro plant	1	200000	140000	50000	20000	I.Rs.
Chulhas, 50 families	50	12500	0	0	12500	I.Rs.
CFL's 4 per family*50	200	44000	0	0	44000	I.Rs.
CFLs, mayor office, clinique	5	1100	0	0	1100	I.Rs.
CFLs, 4 street lamps	4	880	0	0	880	I.Rs.
Total for energy solutions		258480	140000	50000	78480	I.Rs.
Additional costs:						
Minigrid	1	200000	150000	0	50000	I.Rs.
Street lamps	4	28000	0	0	28000	I.Rs.
Water pump	1	4000	0	0	4000	I.Rs.
Small cold storage	1	10000	0	0	10000	I.Rs.
Total additional costs		242000	150000	0	92000	I.Rs.
Investment, total		500480	290000		170480	I.Rs.
Investment per family					5683	I.Rs.



"pico-hydro+chulha" Energy Balance	Fuel (kWh/year)				Electricity		Total		Efficiency*		End-use (kWh/yr)
	Wood	Dung/waste	Gas	Diesel/kerosene		All sources	Fuel	Electricity	All energy		
Stove, improved chulha	218,700					218,700	24%		52,488		
Stove, type 2 (dung)		0				0	11%		0		
Light				0	2,930	2,930	0.3%	60%	1758		
Radio/TV					3,284	3,284		50%	1642		
Refrigerator					835	835		50%	1642		
Village grinder (agriculture)				2000	3,600	5,600	15%	60%	2460		
Water pump (other)			914		360	360		75%	270		
Tractor (agriculture)				60,000		60,000	20%		12000		
	218,700	0	914	62,000	11,009	292,624			72,717		
Costs, total	4860	0	1440	155000	41200	202500	Rs/year****				
Cost/household, excl. Agr.	162	0	29	0	0	162	Rs/year per family in average				
Income in village	4860	0		0	9200	14060	Rs/yr that stay in village**				
Work	89	0		2		91	Work in hours/day***				
							CO2 emissions kg/y				

* Electric efficiencies are relative to best available technology.

** It is estimated that 20% of battery costs are going to local shop/seller in the village

*** It is estimated that it takes 1/2 hour to collect 1 kg firewood and 1/2 hour to collect and dry 1 kg cow dung

**** For electricity is estimated that the annual cost of 10,000 Rs. + 31.200 Rs. to pay for investments in pico-hydro facility

Annual payments "pico-hydro+chulhas"	
Energy payment incl. Loan for micro-hydro incl. mini grid*	202500 I.Rs/yr
Payment, excl. Agriculture	34028 I.Rs/yr
Payment per family excl. Agriculture, average	1134 I.Rs/yr
Payment per family compared with present situation (- is savings), average	-779 I.Rs/yr
Payment per family compared with future "BAU"(- is savings), average**	-3626 I.Rs./yr

* Loan repayment is assumed to be annually 10% of the total value of the loan (low-cost loan)



INFORSE-South Asia Project partners in Sri Lanka in April 2005

Map of Countries under the INFORSE South Asia Region

INFORSE SOUTH ASIA COORDINATOR:

Integrated Sustainable Energy and Ecological Development Association (INSEDA)

Attn: Raymond Myles, INFORSE Regional Coordinator (South Asia)
Address: H No: C-37, 1st Fl, Next to Car Life Centre, Jeewan Park, Pankha Road, Uttam Nagar, N. Delhi-110059, India
Ph: 6450 0750, Telefax: +91 11-2554 4905; (Mob): (0) 9212014905 & (0) 9899094905
Email: raymyles@bol.net.in; ray.myles06@gmail.com and ray_myles05@yahoo.co.in
Website: www.inseda.org; www.inseda.info and www.inforse.org/asia

INFORSE NATIONAL FOCAL POINTS:

Grameen Shakti (GS)

Attn: Dipal Barua, INFORSE National Focal Point (Bangladesh)
Address: Grameen Bank Bhaban. Mirpur-2, 1216 Dhaka, Bangladesh
Ph: +880-2 9004081,
Fax: +880-2 9004314 Ext. 103
Email: g_shakti@grameen.net; Website: www.gshakti.com

All India Women's Conference, Rural Energy Dept. (AIWC)

Attn: Lalita Balakrishnan, INFORSE National Focal Point (India- Women NGOs)
Address: Sarojini House, 6 Bhagwandas Road. 110001 New Delhi, India
Ph: 91 112-3389680/-3381165; Fax: +91 112-3384092- 3388567
Email: aiwcctc@nda.vsn!.nci.in; aiwci@isatyam.in & lalitabalakrishnan@gmail.com; Website: www.aiwc.org

Sustainable Development Agency (SDA)

Attn: Fr. Mathew Vadakemuriyil, INFORSE National Focal Point (India-General NGOs)
Address: Parathodu. Kanjirapally, Kottayam Dist. 686512 Kerala, India
Ph: +91-4828-270546, Fax: -270646.
Email: infarm@rediffmail.com

Centre for Rural Technology (CRT)

Attn: Ganesh Ram Shrestha, INFORSE National Focal Point (Nepal)
Address: Tri pure swore. P.O.Box 3628, Kathmandu, Nepal
Ph: +977 1-260165, Fax:+977 1-257922.
Email: cn@wlink.com.np, org, info@crtnepal.org; Website: www.crtnepal.org

Integrated Development Association (IDEA)

Attn: R.M. Amerasekera, INFORSE National Focal Point (Sri Lanka)
Address: GahnaduwBwatte Rd, Kundasale, Sri Lanka
Ph: +94 81-24233; Fax: +9481-4470649
Email: idea@sltnet.lk and amare@ids.lk; Website: www.inforse.org/asia

INFORSE INTERNATIONAL SECRETARIAL:

INFORSE-Europe/OVE

Attn: Gunnar Boye Olescn, Coordinator INFORSE Europe & INFORSE International
Address: Gl. Kirkevej 82, DK-8530, Hjortshaj. Denmark
Ph: +45 86227000; Fax: +45 86227096
E-mail: ove@inforse.org and inforse@gmail.com; Website: www.inforse.org

